



# The black Sheep (age 6-12 years)

Ref. KP4007

Last check: 30/11/2023

Pag. 1/3

EN-1176-1: 2018

EN-1176-2: 2018+AC: 2020

EN-1176-3: 2018



SERIE  
**ANIMALS**  
SERIES



### Technical information.

**Animal:** Build in poliester painted by mass, with gel-coat of predominant color and anti-graffiti treatment.

**Structure:** Internal build in galvanized steel pipe.

**Surface:** Walk zone finished in high resistance EPDM.

**Anchoring:** Galvanized steel for mounting on concrete foundation.

### Technical data.

**Assembly:** 2 pers. 2 hours.

**Weight:** 300 Kg.

**Total height:** 2,4 m.

**Free fall height:** 1,50 m.

**Safety area:** 33 m<sup>2</sup>. (example)

**Biggest piece dimension:** 3 m.

**Spare pieces availability:** 3 years.

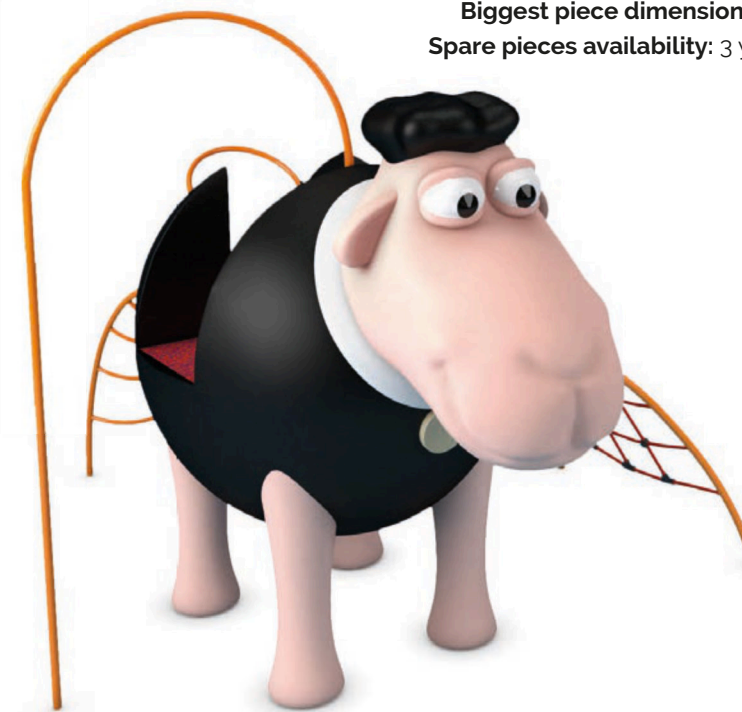

Example of installation with accessories.



C/ Foia, 13  
Pl. Alquería  
de Moret  
46210 Picanya  
(Valencia)



+34 963 313 677



kiwi@kiwipw.com



kiwiplaygrounds.com

The company reserves  
the right to perform  
any modification or  
change in their products.

**MODULES**



# The black Sheep (age 6-12 years)

Ref. KP4007

Last check: 30/11/2023

Pag. 2/3

EN-1176-1: 2018

EN-1176-2: 2018+AC: 2020

EN-1176-3: 2018



SERIE  
**ANIMALS**  
SERIES

Safety area 33 m<sup>2</sup>  
(with example elements)

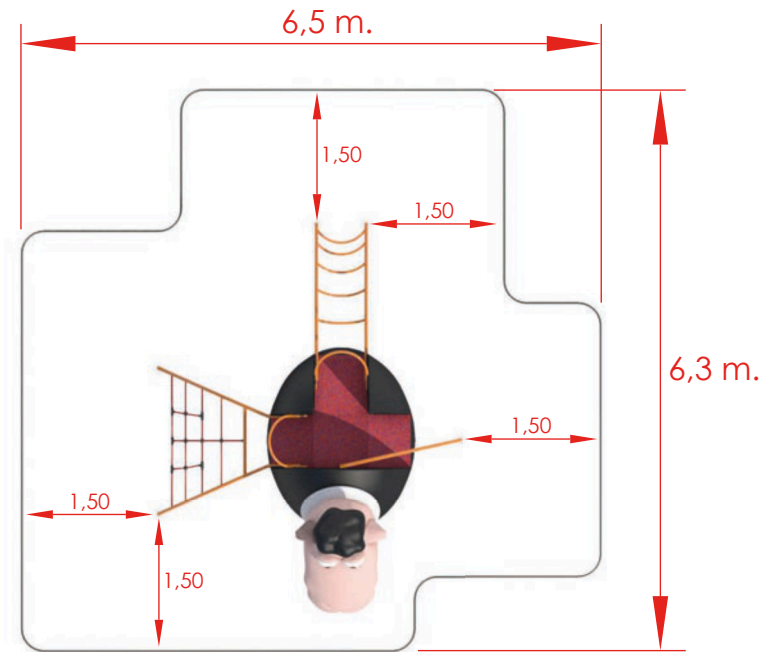

General dimensions (mm.)

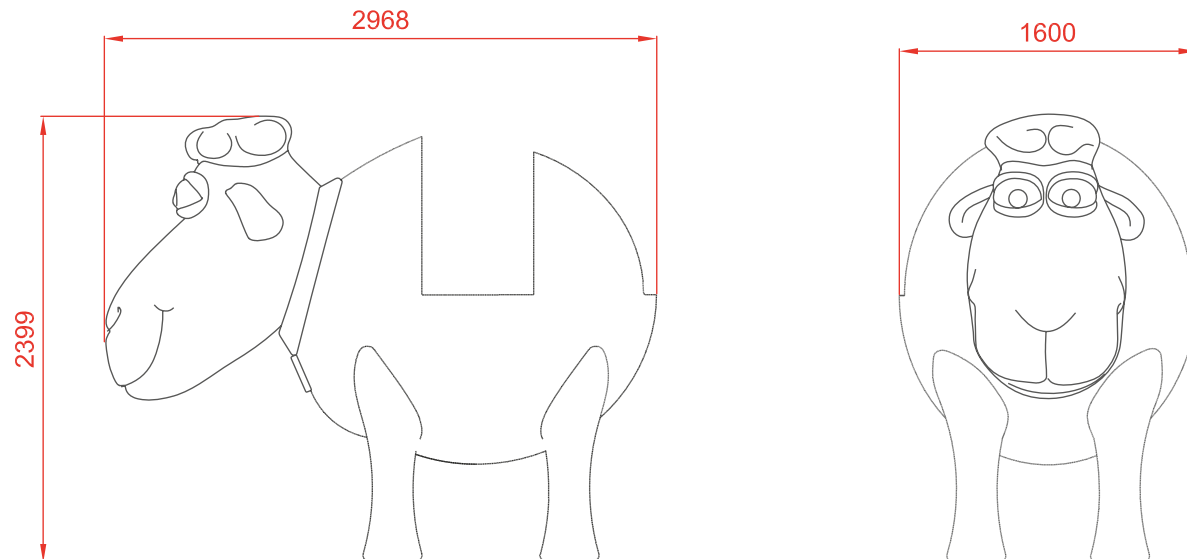

C/ Foia, 13  
Pl. Alquería  
de Moret  
46210 Picanya  
(Valencia)



+34 963 313 677



kiwi@kiwipw.com



kiwiplaygrounds.com

The company reserves  
the right to perform  
any modification or  
change in their products.

**MODULES**



# The black Sheep (age 6-12 years)

Ref. KP4007

Last check: 30/11/2023

Pag. 3/3

EN-1176-1: 2018

EN-1176-2: 2018+AC: 2020

EN-1176-3: 2018



SERIE  
**ANIMALS**  
SERIES

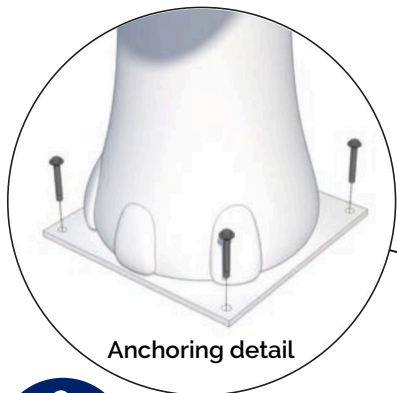

Anchoring detail



C/ Foia, 13  
Pl. Alquería  
de Moret  
46210 Picanya  
(Valencia)



+34 963 313 677



kiwi@kiwipw.com



kiwiplaygrounds.com

The company reserves  
the right to perform  
any modification or  
change in their products.

Dimensions of the concrete slab of the example .

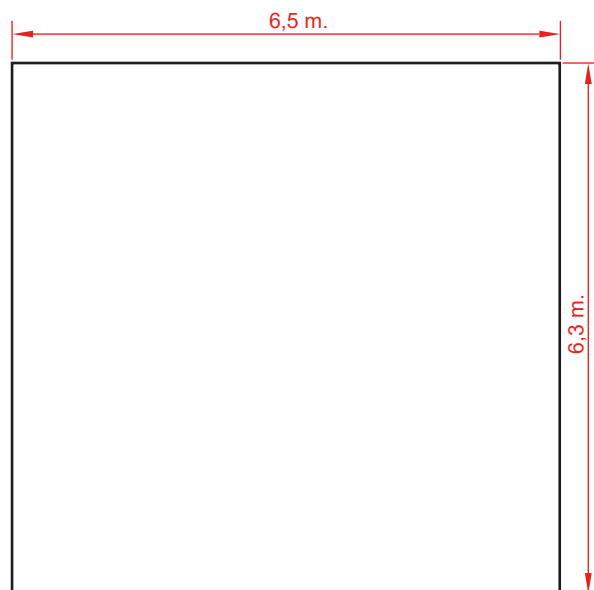

### Installation.

Screwed to concrete floor using expansion plugs or threaded rod and epoxy. Finished with compacted material coating either continuous wet-pour rubber surfacing or rubber tiles.

### Maintenance:

Checking: all fixing points, screws and bolts must be periodically checked and tightened again if necessary. The checking date must be annotated in order to establish a control.

### Inspections:

1. Routine visual inspection. An eye and functional inspection will be performed to verify that you have not suffered any vandalism damage.
2. Functional inspection. This inspection will be carried out with a periodicity of 1 to 3 months and attention should be paid to the components "sealed for life" and the equipment whose stability depends on a post.
3. Annual inspection. A complete inspection of the whole set will be carried out in order to verify that it meets all the sections of the standard and that it has not been modified.

Anchoring detail

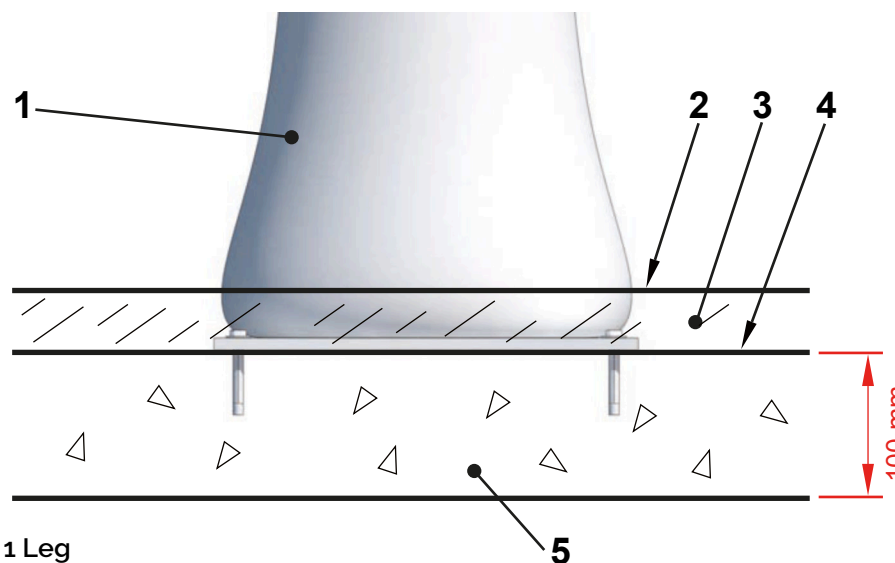

- 1 Leg
- 2 Playing surface
- 3 Rubber
- 4 Foundation's upper layer
- 5 Foundation

**MODULES**