



Ladder (age 6-12 years)

Ref. KP4015

Last check: 01/02/2020

Pag. 1/2

EN-1176-1: 2017

EN-1176-2: 2017+AC: 2019

EN-1176-3: 2017



SERIE
ANIMALS
SERIES

Technical information.

Structure: Manufactured in Ø40 mm.
curved tubular steel.
Welded to anchor plate.

Finishes: Baked paint in various colors.

Technical data.

Assembly: 2 pers.

Weight: 100 Kg.

Total height: 2,28 m.

Free fall height: 1,50 m.

Dimensions: h2,28 x 0,6 x 1,7 m.



Installation example.



C/ Foia, 13
P.I. Alquería
de Moret
46210 Picanya
(Valencia)



+34 963 313 677



kiwi@kiwipw.com



kiwiplaygrounds.com

The company reserves
the right to perform
any modification or
change in their products.

ACCESSORIES



Ladder (age 6-12 years)

Ref. KP4015

SERIE
ANIMALS
SERIES

Last check: 01/02/2020

Pag. 2/2

EN-1176-1: 2017

EN-1176-2: 2017+AC: 2019

EN-1176-3: 2017



Installation.

Anchored to the animal module with 8 screws and to the floor with 4 expansion bolts. Finished with compacted material coating either continuous wet-pour rubber surfacing or rubber tiles.

Maintenance:

Checking: all fixing points, screws and bolts must be periodically checked and tightened again if necessary. The checking date must be annotated in order to establish a control.

Inspections:

1. Routine visual inspection. An eye and functional inspection will be performed to verify that you have not suffered any vandalism damage.
2. Functional inspection. This inspection will be carried out with a periodicity of 1 to 3 months and attention should be paid to the components "sealed for life" and the equipment whose stability depends on a post.
3. Annual inspection. A complete inspection of the whole set will be carried out in order to verify that it meets all the sections of the standard and that it has not been modified.

General dimensions (mm.)

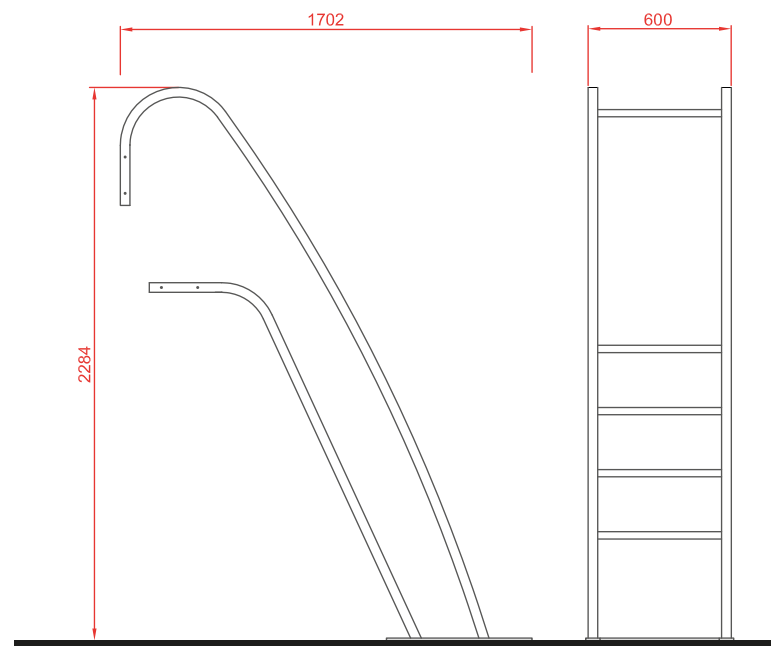

C/ Foia, 13
P.I. Alquería
de Moret
46210 Picanya
(Valencia)



+34 963 313 677

kiwi@kiwipw.com

kiwiplaygrounds.com

The company reserves
the right to perform
any modification or
change in their products.

ACCESSORIES