

# TECHNICAL DATA



Ref.: BS02

Rowing



Made with structural metal profiles.  
Thermo-lacquered paint treatment with primer.  
High density polyethylene with UV protection.  
Stainless steel screws.

**Users:** 1

**Ages:** Users taller than 1,40 m.

**Instructions:** Sit on the seat and place your feet in the stirrups. Place the hands as if taking the oars of a boat and perform the rowing movement.

**Functions:** Strengthen upper and lower limbs, chest and abdomen.

**Warning:** Pull gently and back gently so as not to strain the abdominal muscle.



### LATERAL VIEW

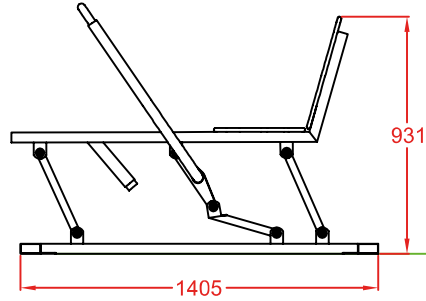

### FRONT VIEW

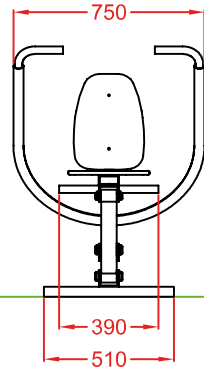

### FOUNDATION

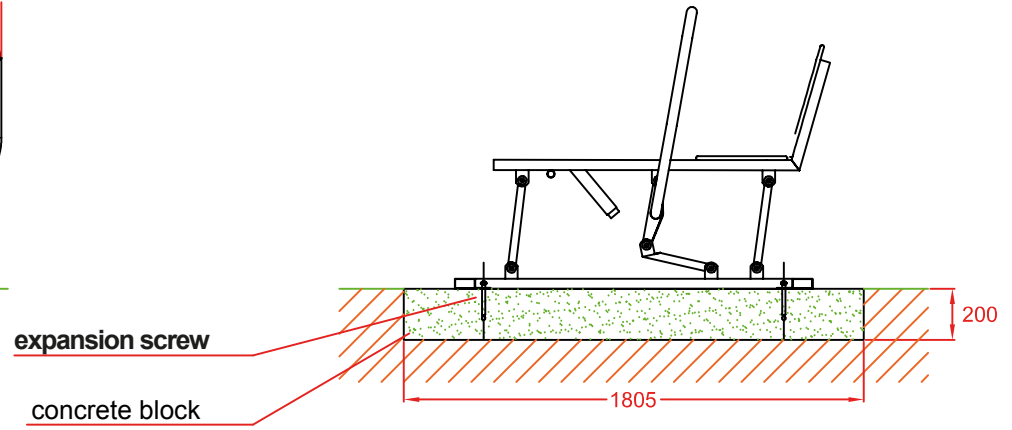

### TOP VIEW

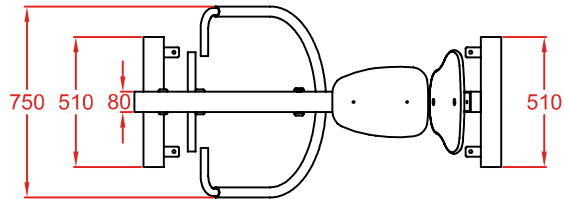

### TOP VIEW SLAB

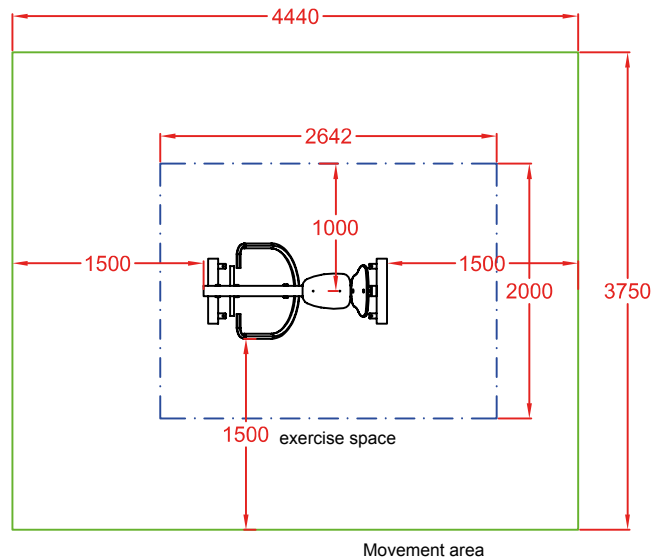
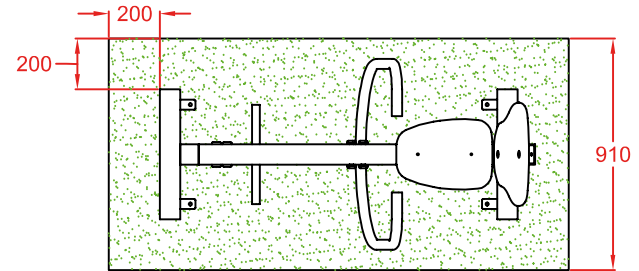

Drawn		VIEWS AND FOUNDATIONS	Ref: BS02
Reviewed			
Passed			
Description: METALLIC BIO-HEALTHY DEVICE "ROWING"		Scale:	Full number: 2/2
		Date: 09-03-2018	