

TECHNICAL DATA

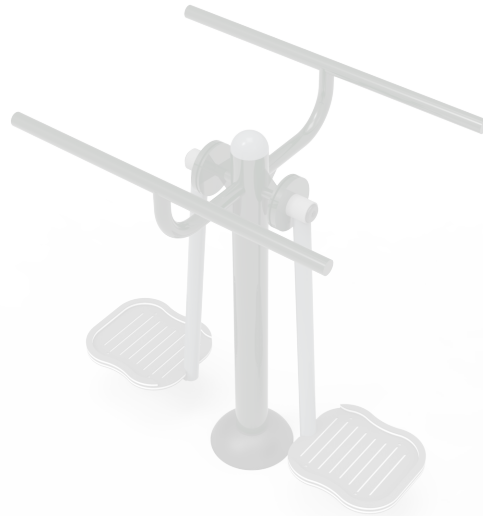

Ref.: BS06

Surf



Made with structural metal profiles.
Thermo-lacquered paint treatment with primer.
High density polyethylene with UV protection.
Stainless steel screws.

Users: 2 (one user per bracket).

Ages: Users taller than 1,40 m.

Instructions: Place both feet on the stirrup, hold on to both hands and use the movement of the waist to move the legs like a pendulum.

Functions: Activation and reinforcement of the waist, improvement of cardiopulmonary function.

Warning: Get on the equipment only when the stirrup is stable.



LATERAL VIEW

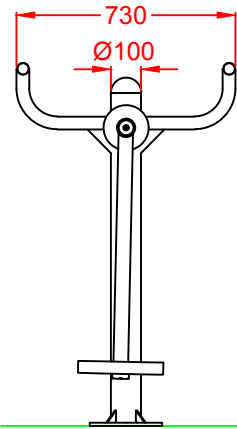

FRONT VIEW

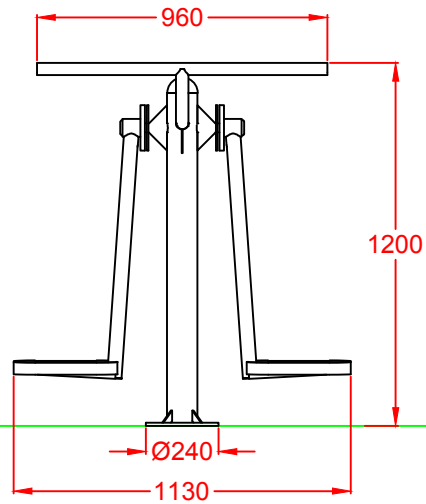

FOUNDATION

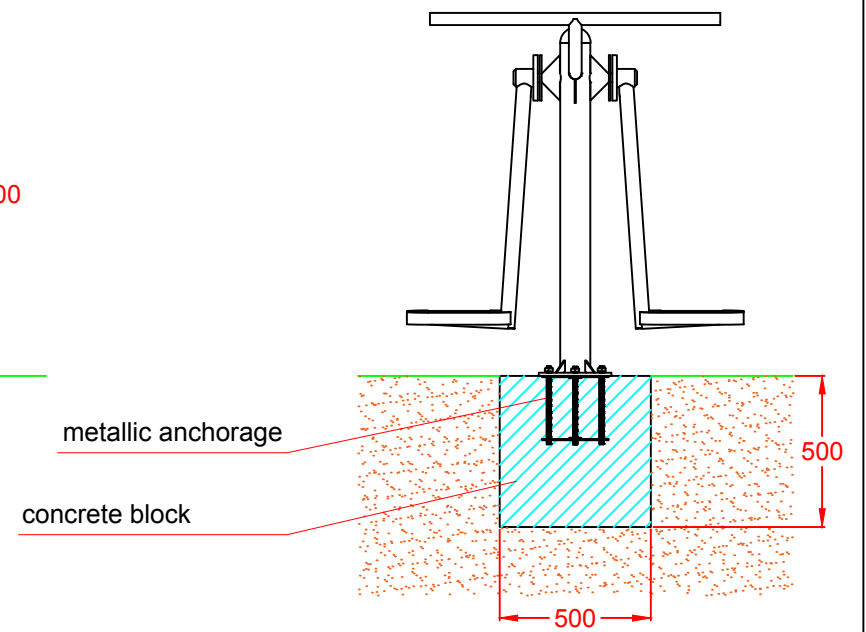

TOP VIEW

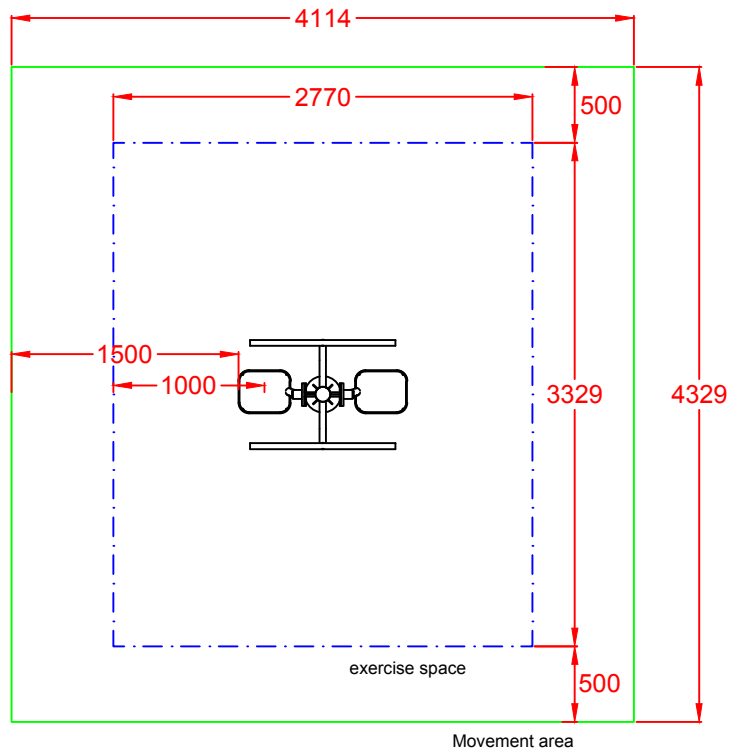
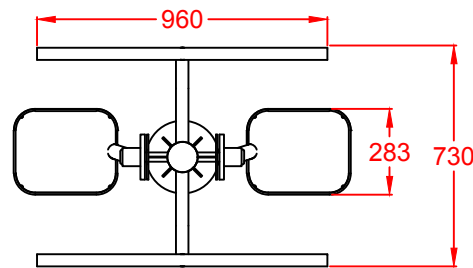

Drawn		VIEWS AND FOUNDATIONS		Ref: BS06
Reviewed				
Passed				
Description:		Scale:	Full number:	
METALLIC BIO-HEALTHY DEVICE "SURF"		Date: 03-08-2016	2/2	