

TECHNICAL DATA



Ref.: BS09

Navigation



Made with structural metal profiles.
Thermo-lacquered paint treatment with primer.
Wood Compacmel.
Stainless steel screws.

Users: 2 (one per wheel)

Ages: Users taller than 1,40 m.

Instructions: Facing the wheel place both hands on the handlebars and turn the wheel clockwise. Then turn in the opposite direction. repeat the operation by turning the body into different positions.

Functions: Development and strength of the upper limbs and especially the wrists, elbows, shoulders and waist. Cardiopulmonary strengthening.

Warning: Pay special attention to those with lumbar problems and vertebral. Children must be supervised by an adult.



LATERAL VIEW

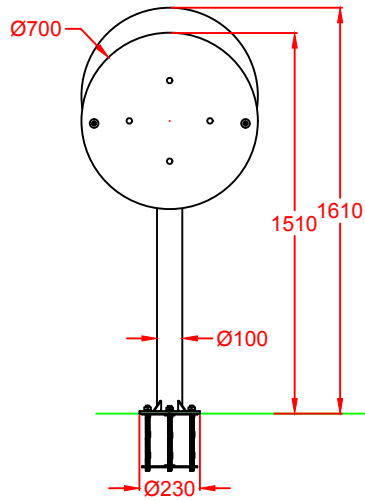

FRONT VIEW

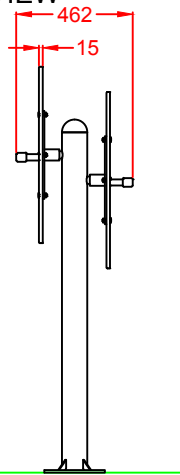

FOUNDATION

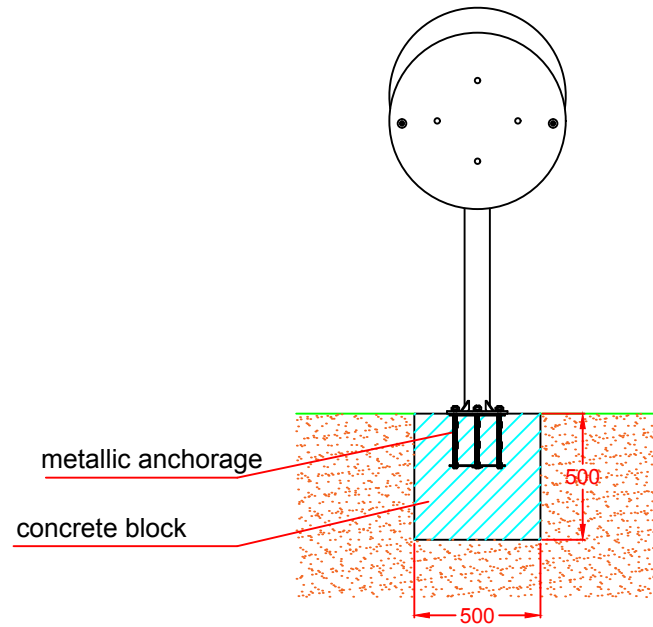

TOP VIEW

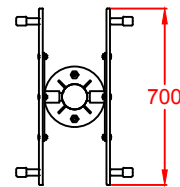
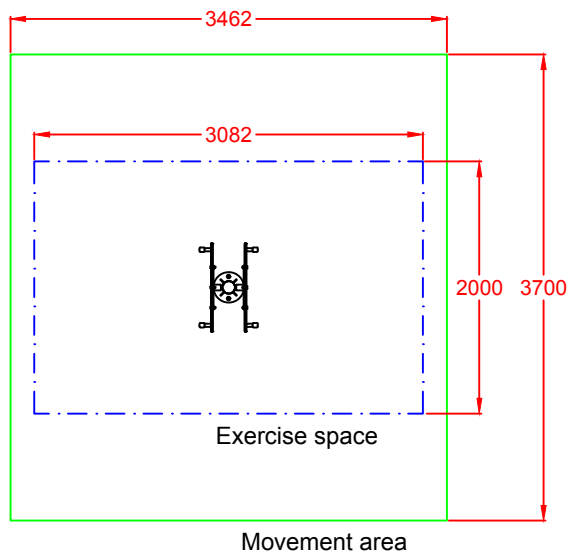

Drawn		VIEWS AND FOUNDATIONS	Ref: BS09
Reviewed			
Passed			
Description:		Scale:	Full number:
METALLIC BIO-HEALTHY DEVICE "NAVIGATION"		Date: 03-08-2016	2/2