

TECHNICAL DATA

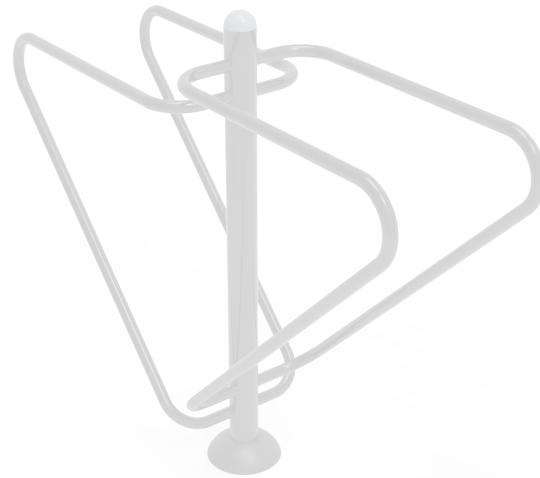

Ref.: BS13

Parallels



Made with structural metal profiles.
Thermo-lacquered paint treatment with primer.
Stainless steel screws.

Users: 2

Ages: Users taller than 1,40 m.

Instructions: With both hands hold on tightly to the horizontal bars. Lift the body up and down.

Functions: Improves the strength of the muscles of the upper extremities, shoulders, chest and back.

Warning: When used by children, adult supervision required.



FRONT VIEW

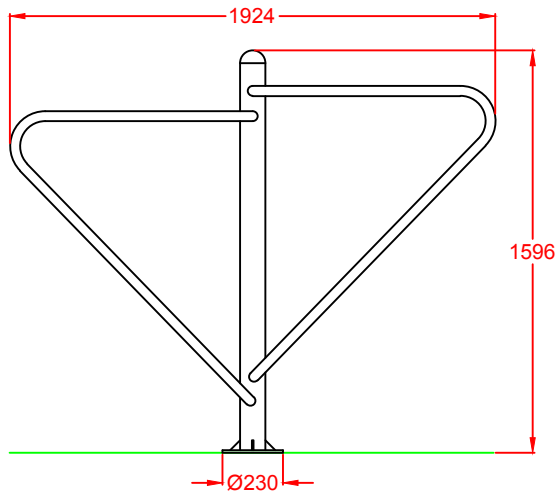

TOP VIEW

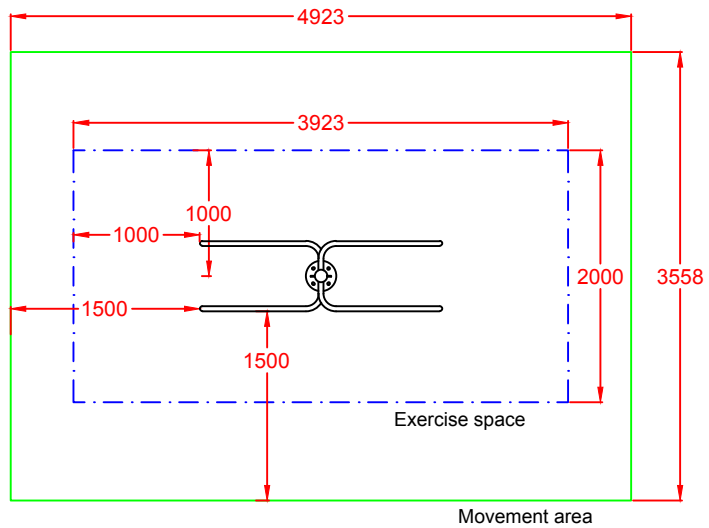
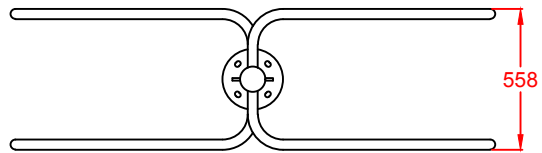

FOUNDATION

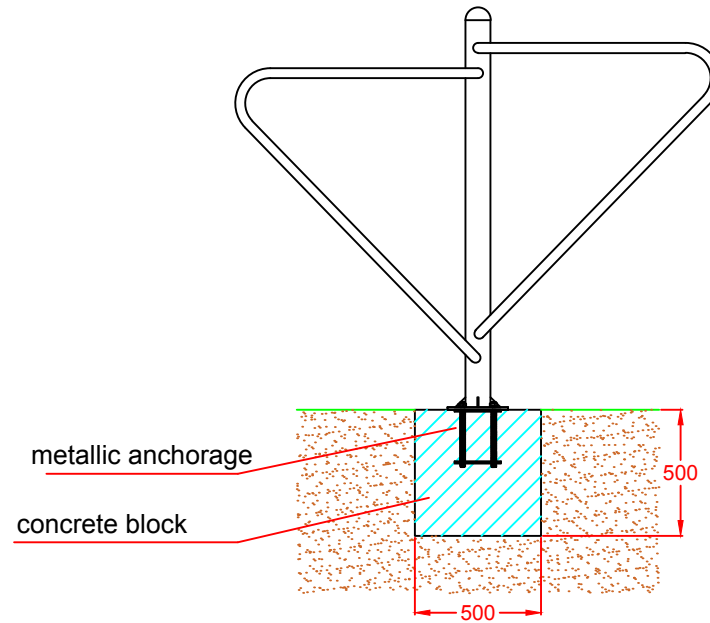

Drawn		VIEWS AND FOUNDATIONS	Ref: BS13
Reviewed			
Passed			
Description: METALLIC BIO-HEALTHY DEVICE "PARALLELS"		Scale:	Full number: 2/2
		Date:	03-08-2016