

TECHNICAL DATA



Ref.: BS14

Spinning



Made with structural metal profiles.
Thermo-lacquered paint treatment with primer.
High density polyethylene with UV protection.
Stainless steel screws.

Users: 1

Ages: Users taller than 1,40 m.

Instructions: Take hold of the two handles and place your feet on the stirrups. move legs in the direction of travel.

Functions: Development of muscular strength in the lower limbs, as well as waist. Strengthening of cardiopulmonary function.

Warning: Do not make sudden movements. A single user. Special attention to upload and when leaving the equipment. When used by children, adult supervision required.



LATERAL VIEW

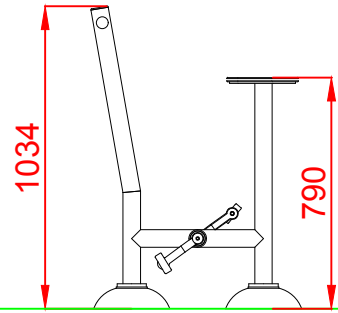

FRONT VIEW

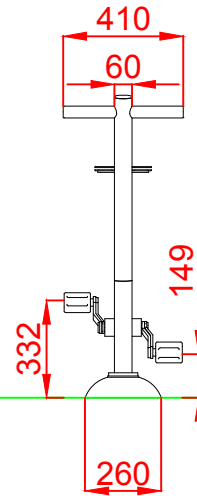

FOUNDATION

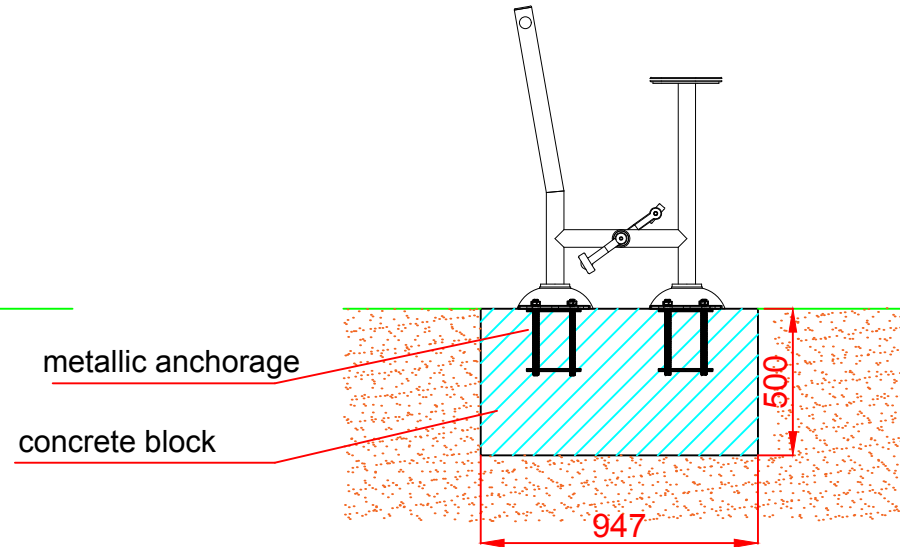

TOP VIEW

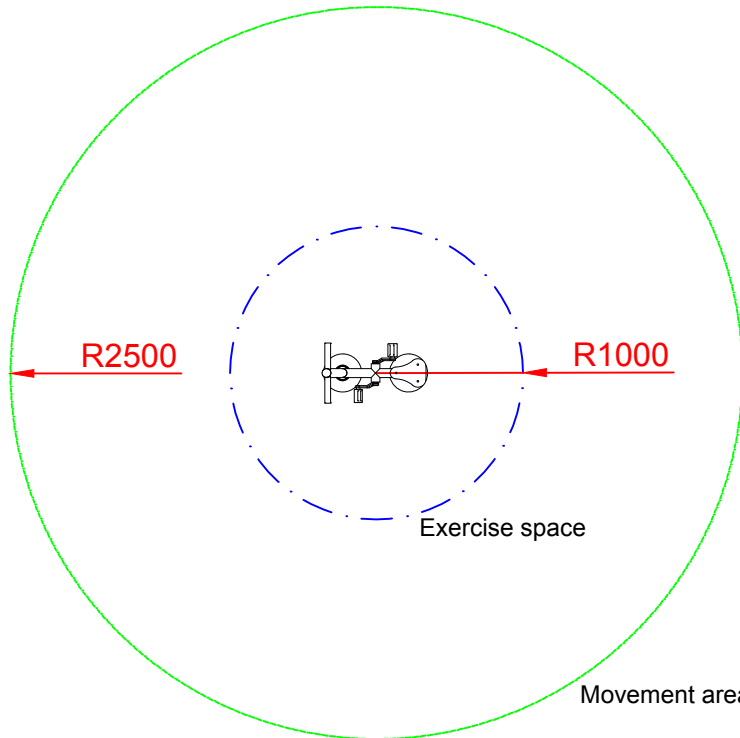
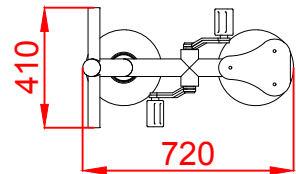

Movement area: 19,63 m²
 Exercise space: 3,14 m²
 Scale 1:2

Drawn		VIEWS AND FOUNDATIONS	Ref: BS14
Reviewed			
Passed			
Description:		Scale:	Full number:
METALLIC BIO-HEALTHY DEVICE "SPINNING"		Date: 26-11-2019	2/2