

# DOCUMENTACIÓN TÉCNICA

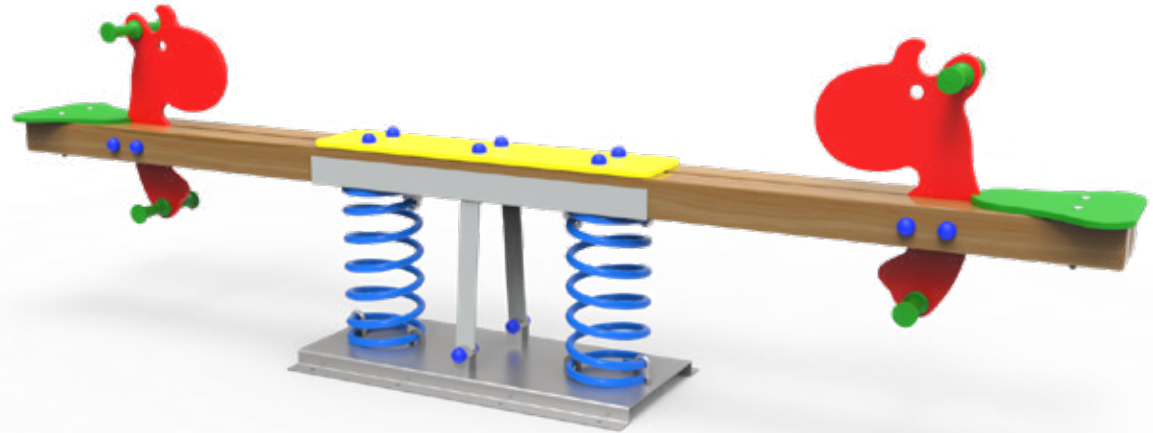
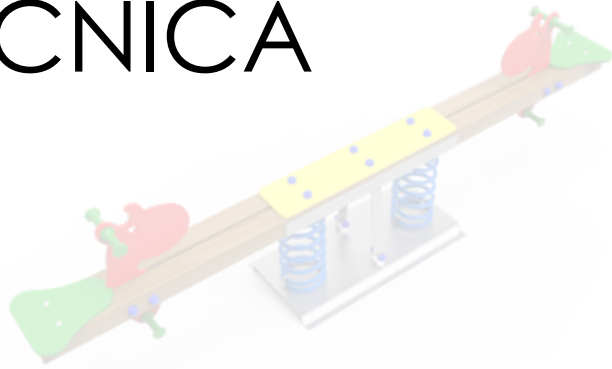

Ref.: BLC03

## Balancín “Los hipopótamos”

UNE EN 1176-1:2018

UNE EN 1176-6:2018



Altura libre de caída: 0,52 m  
Edad recomendada de uso: de 3 a 9 años  
Muelles con antipinzamiento  
Componentes plásticos: Polietileno de alta densidad con protección UV  
Madera de pino tratada en autoclave nivel IV  
Muelle termolacado  
Componentes metálicos galvanizados  
Tornillería protegida con tapones de polipropileno

ALZADO

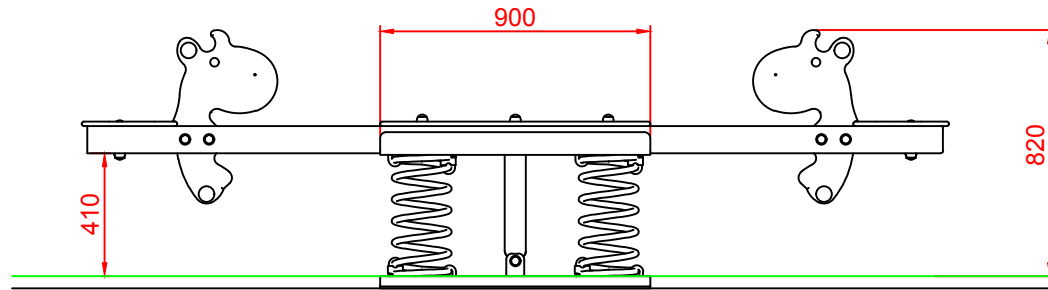

PERFIL

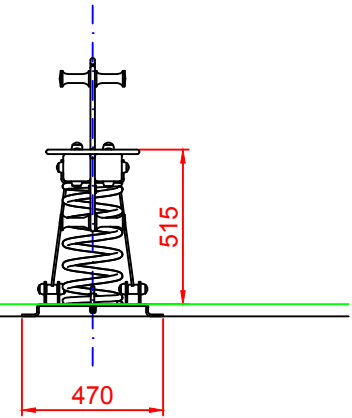

PLANTA

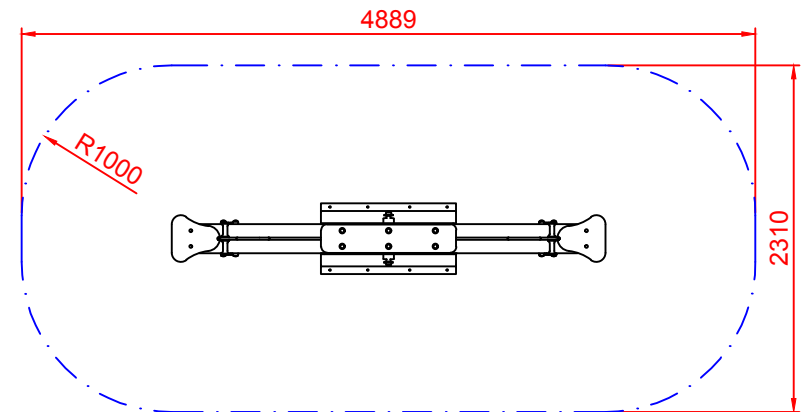
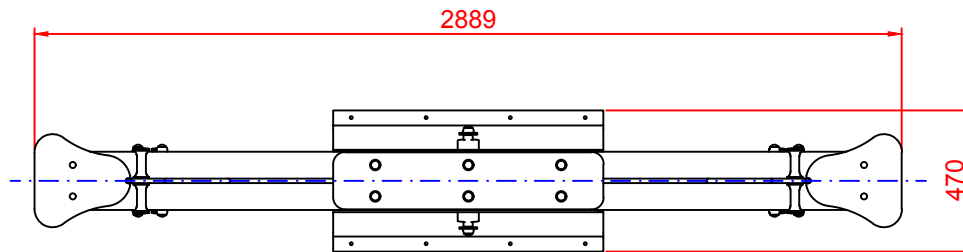

ÁREA DE SEGURIDAD  
Superficie= 10,44 m<sup>2</sup>  
E:1/2

|                            |  |                             |   |       |
|----------------------------|--|-----------------------------|---|-------|
| Dibujado                   |  | PLANO 1<br>VISTAS GENERALES | Ref:  | BLC03 |
| Revisado                   |  |                             |  |       |
| Aprobado                   |  |                             |   |       |
| Descripción:               |  | Escala:                     | Nº Hoja   |       |
| BALANCÍN "LOS HIPOPÓTAMOS" |  |                             | 2/4   |       |
|                            |  | Fecha:                      | 07-05-2019  |       |

# DETALLES CIMENTACIÓN

ESQUEMA DE CIMENTACIÓN  
EN ARENA

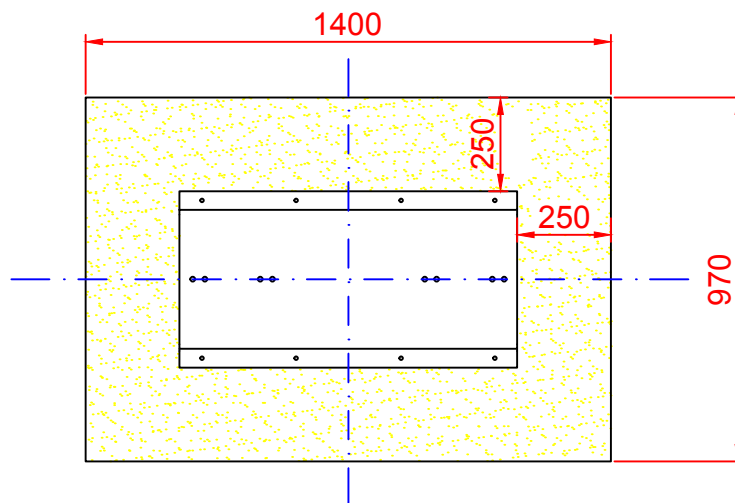
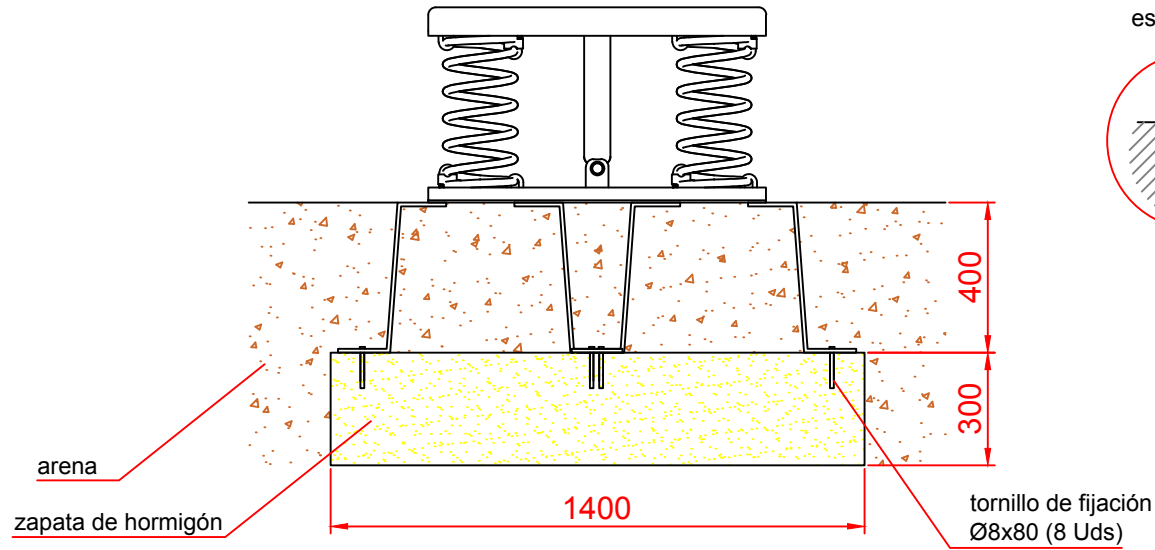

ESQUEMA DE CIMENTACIÓN  
EN HORMIGÓN

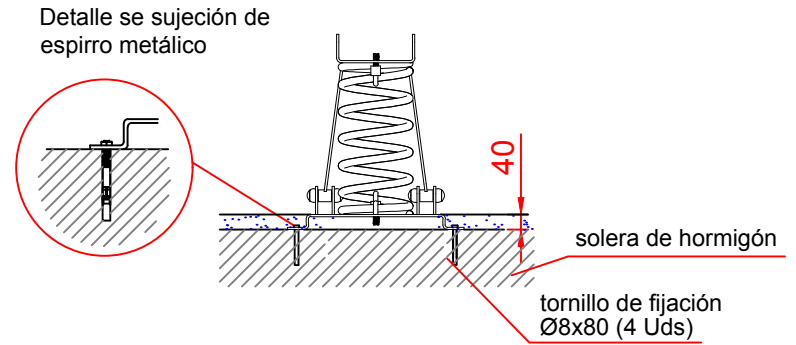

|                            |  |                                  |   |       |
|----------------------------|--|----------------------------------|---|-------|
| Dibujado                   |  | PLANO 2<br>CIMENTACIÓN Y ANCLAJE | Ref:  | BLC03 |
| Revisado                   |  |                                  |  |       |
| Aprobado                   |  |                                  |   |       |
| Descripción:               |  | Escala:                          | Nº Hoja   |       |
| BALANCÍN "LOS HIPOPÓTAMOS" |  |                                  | 3/4   |       |
|                            |  | Fecha:                           | 07-05-2019  |       |

ALZADO

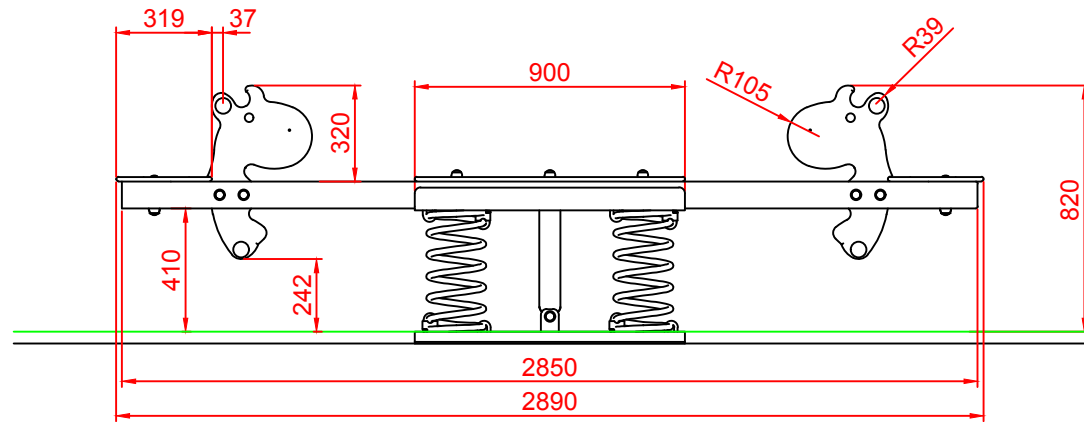

PERFIL

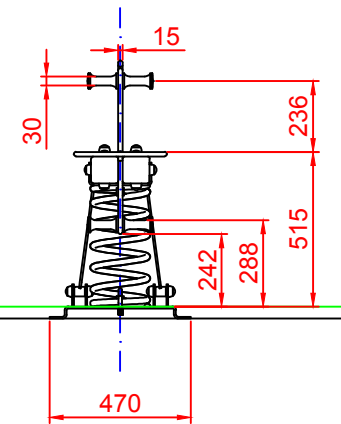

PLANTA

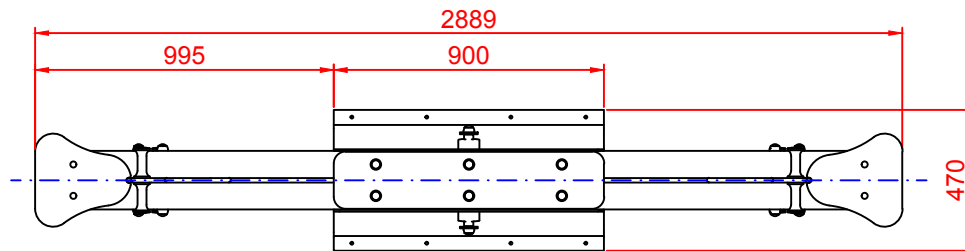

|                            |  |                              |            |   |
|----------------------------|--|------------------------------|------------|---|
| Dibujado                   |  | PLANO 3<br>VISTAS DE DETALLE |            | Ref: BLC03  |
| Revisado                   |  |                              |            |  |
| Aprobado                   |  |                              |            |   |
| Descripción:               |  | Escala:                      | Nº Hoja    |   |
| BALANCÍN "LOS HIPOPÓTAMOS" |  |                              | 4/4        |   |
|                            |  | Fecha:                       | 07-05-2019 |   |