

DOCUMENTACIÓN TÉCNICA



Ref.: CLP08MX

Columpio "Perseo asientos mixtos"

UNE EN 1176-1:2018

UNE EN 1176-2:2018



Altura libre de caída: 1,32 m

Edad recomendada de uso: con asiento cuna de 0 a 3 años

Con asiento plano y asiento nido a partir de 3 años

Componentes plásticos: Polietileno de alta densidad con protección UV

Larguero metálico galvanizado

Cadenas de columpio galvanizadas

Tornillería protegida con tapones de polipropileno

Madera de pino tratada en autoclave Nivel IV

Asiento plano, asiento cuna y asiento nido

ALZADO

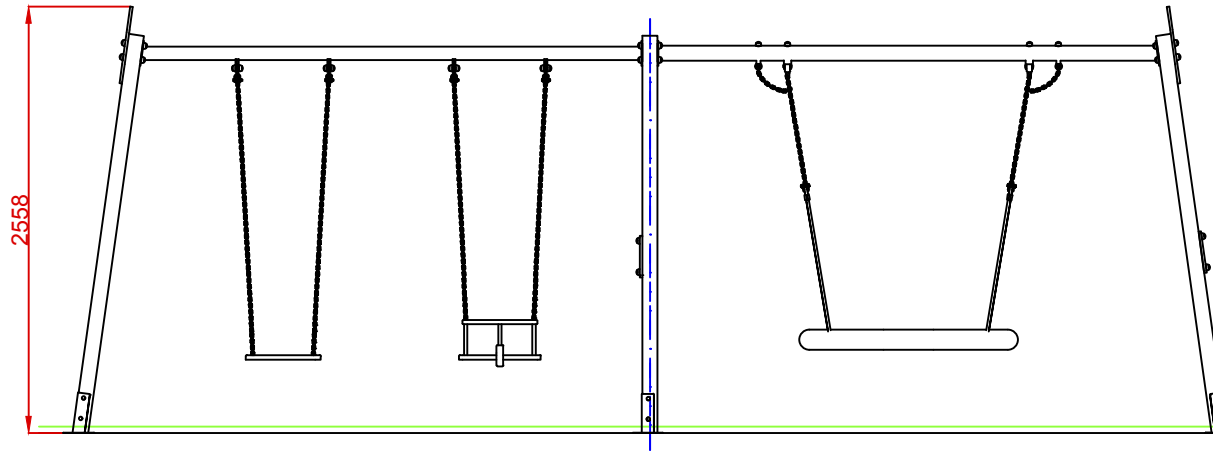

PERFIL

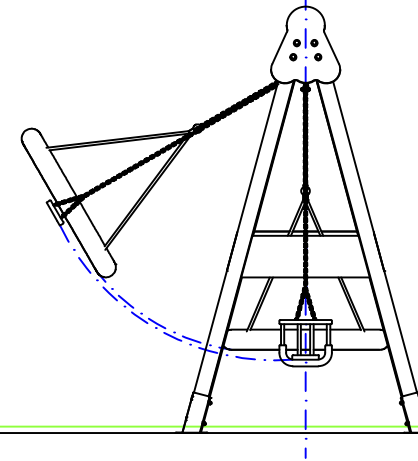

PLANTA

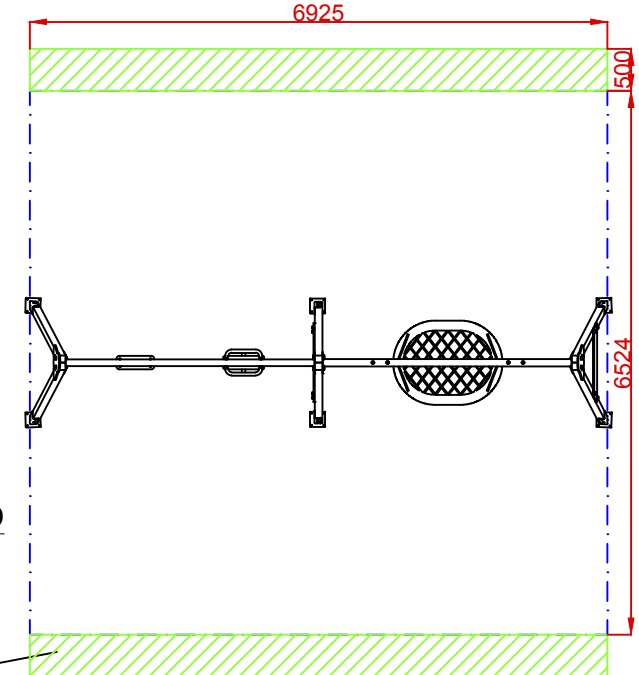
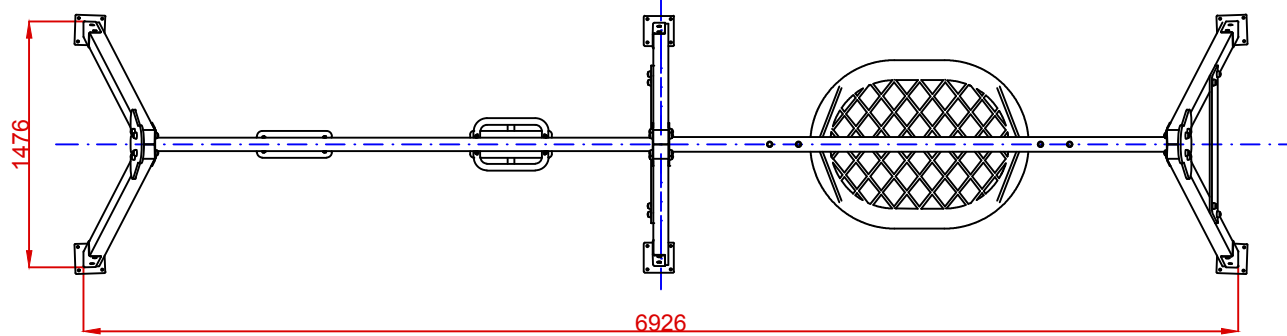

AREA DE SEGURIDAD

Superficie= 45,18 m²

E: 1/2

ZONA LIBRE DE OBSTÁCULOS

Dibujado		PLANO 1 VISTAS GENERALES	Ref:	CLP08MX
Revisado				
Aprobado				
Descripción:		Escala:	Nº Hoja	2/4
COLUMPIO PERSEO ASIENTOS MIXTOS		Fecha:	08/08/2019	

PLANTA CIMENTACIÓN

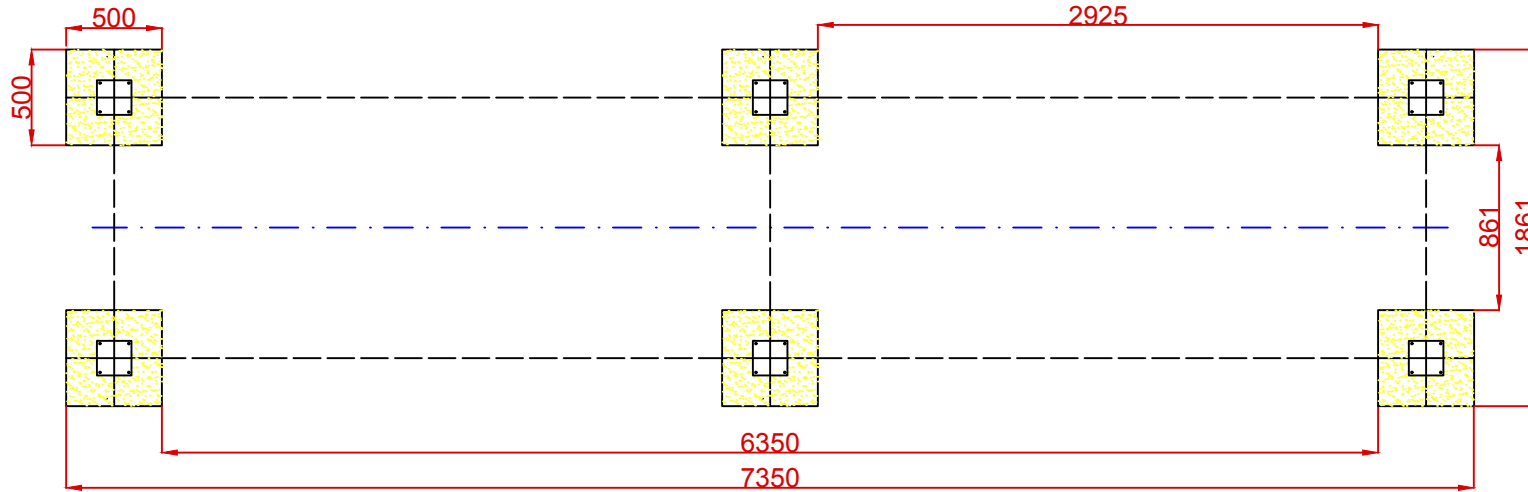

DETALLES CIMENTACIÓN

ESQUEMA DE CIMENTACIÓN
EN ARENA

E: 2/1

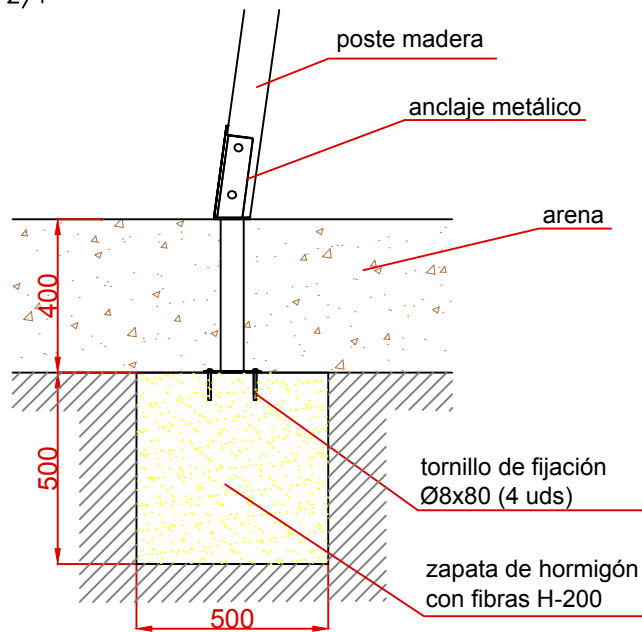

ESQUEMA DE CIMENTACIÓN
EN HORMIGÓN

E: 2/1

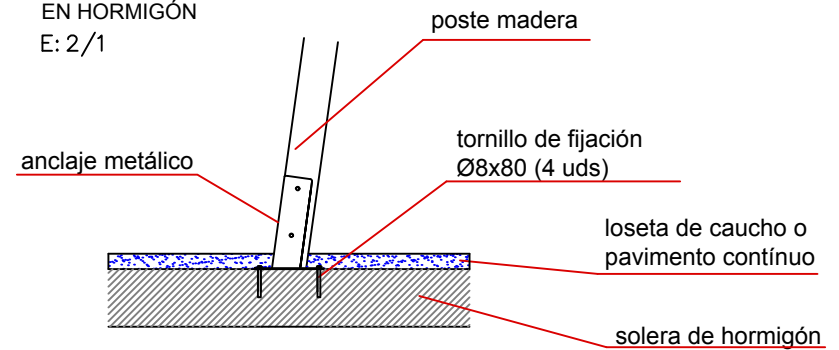

Dibujado		PLANO 2 CIMENTACIÓN	Ref:	CLP08MX
Revisado				
Aprobado				
Descripción:		Escala:	Nº Hoja	3/4
COLUMPIO PERSEO ASIENTOS MIXTOS		Fecha:	08/08/2019	

ALZADO

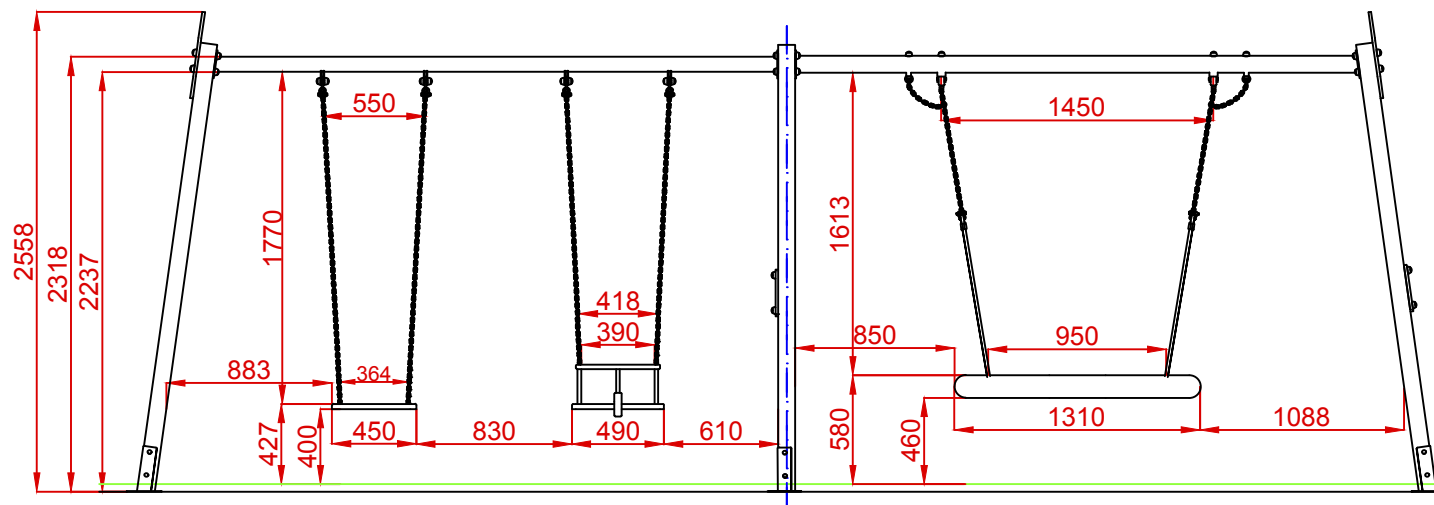

PERFIL

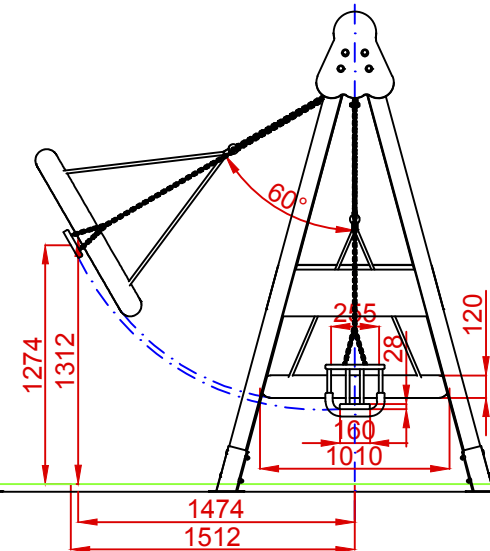

PLANTA

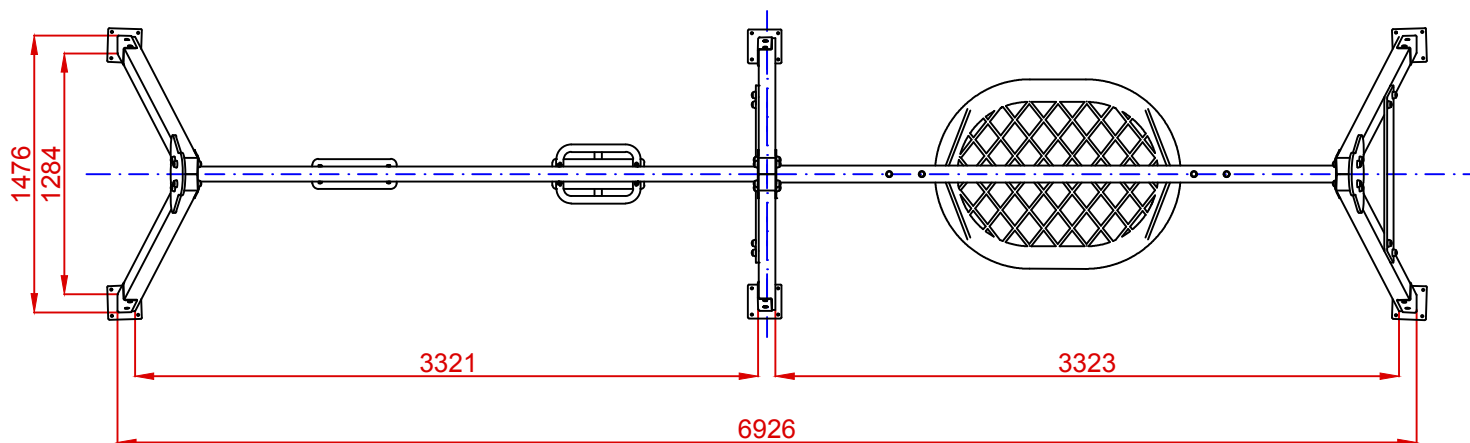

Dibujado		PLANO 3 VISTAS DE DETALLE	Ref:	CLP08MX
Revisado				
Aprobado				
Descripción:		Escala:	Nº Hoja	4/4
COLUMPIO PERSEO ASIENTOS MIXTOS		Fecha:	08/08/2019	