

DOCUMENTACIÓN TÉCNICA



Ref.: COM20

Carrusel Flop

UNE EN 1176-1:2018

UNE EN 1176-5:2021

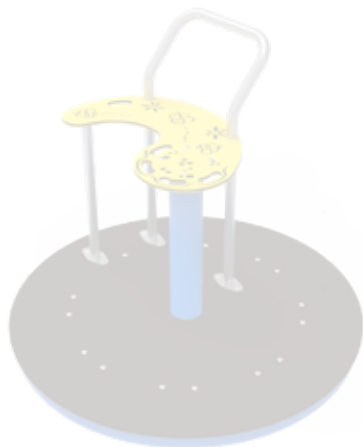

Altura libre de caída: 0,97 m

Edad recomendada de uso: a partir de 3 años

Componentes plásticos: Polietileno de alta densidad con protección UV

Estructura cincada y termolacada

Tablero Contrachapado Antideslizante

Carrusel de Tipo B

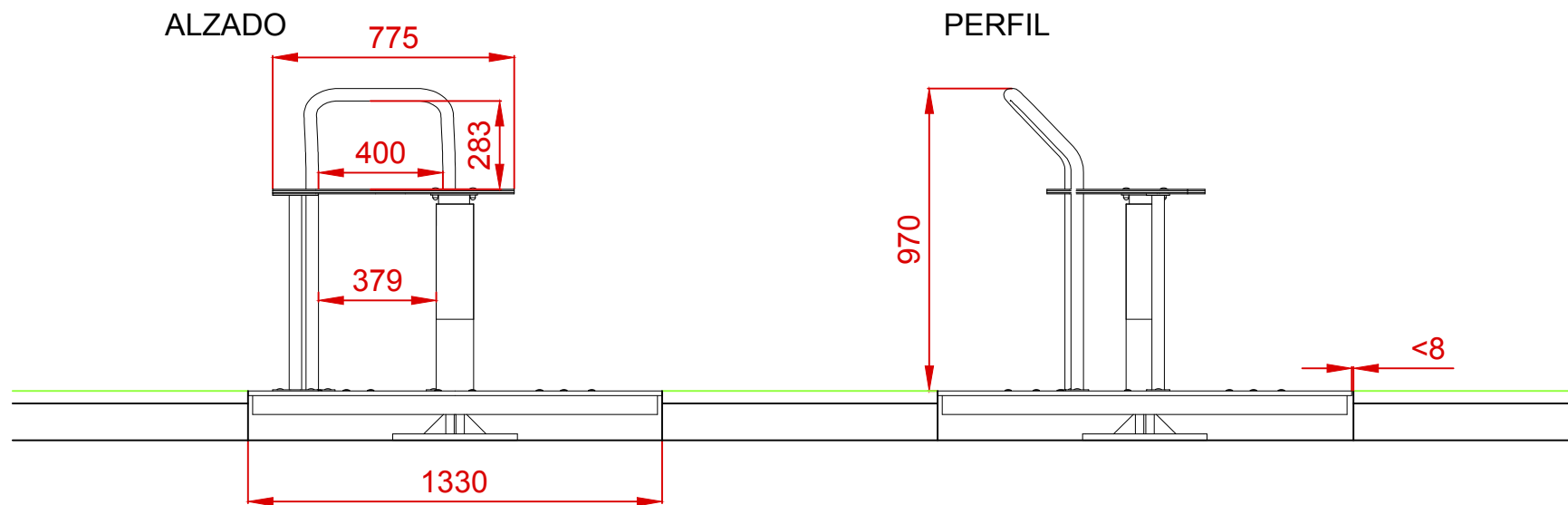

PLANTA

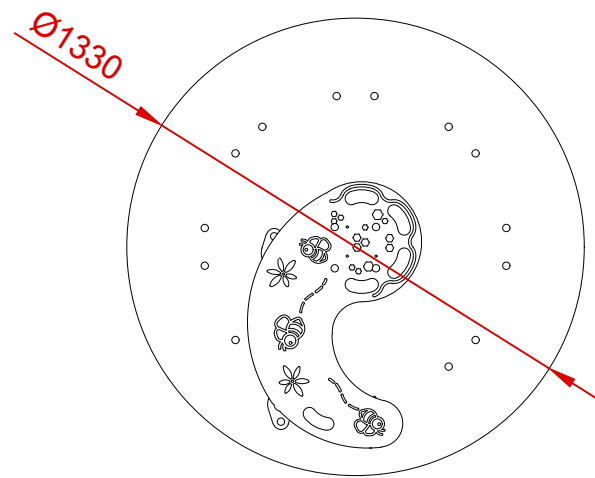

ÁREA DE SEGURIDAD
Superficie= 22,31 m²
E: 1/4

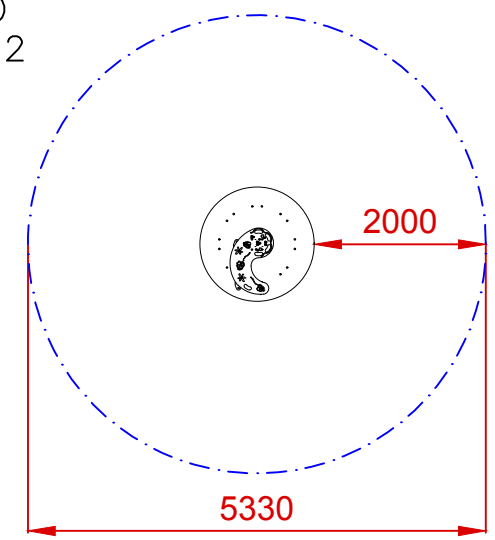

Dibujado		PLANO 1 VISTAS GENERALES	Ref:	COM20
Revisado				
Aprobado				
Descripción:	CARRUSEL FLOP		Escala:	Nº Hoja 2/3
			Fecha:	13/01/2022

DETALLES CIMENTACIÓN

ESQUEMA DE CIMENTACIÓN EN ARENA

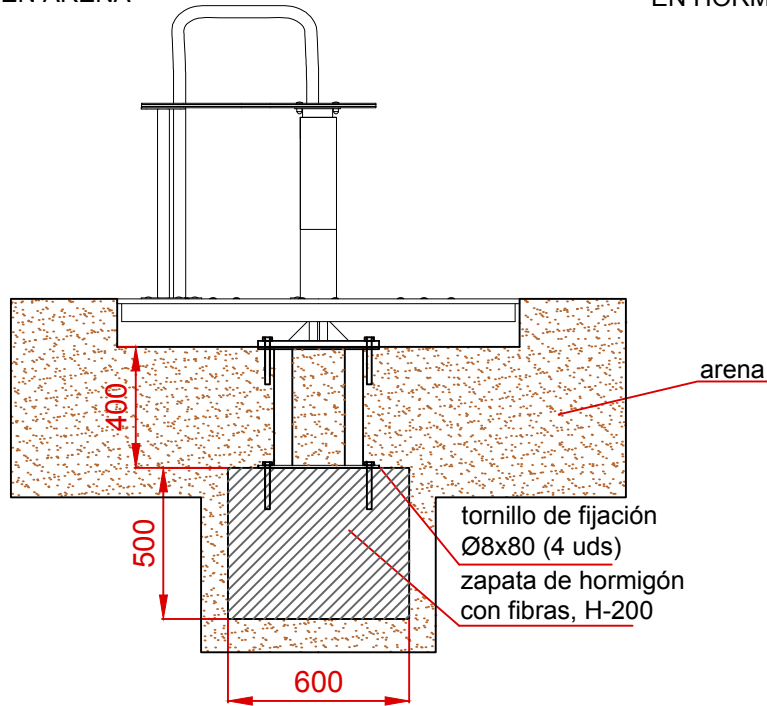

ESQUEMA DE CIMENTACIÓN EN HORMIGÓN

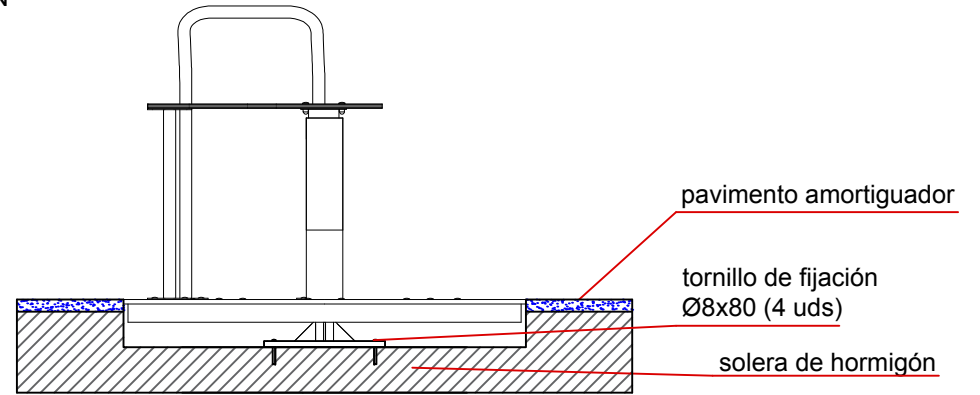

CIMENTACIÓN

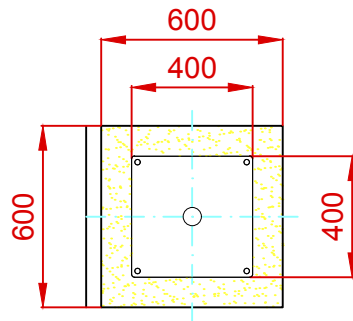

Dibujado		PLANO 2 CIMENTACIÓN Y ANCLAJES	Ref:	COM20
Revisado				
Aprobado				
Descripción:		CARRUSEL FLOP	Escala:	Nº Hoja 3/3
			Fecha:	13/01/2022