

DOCUMENTACIÓN TÉCNICA

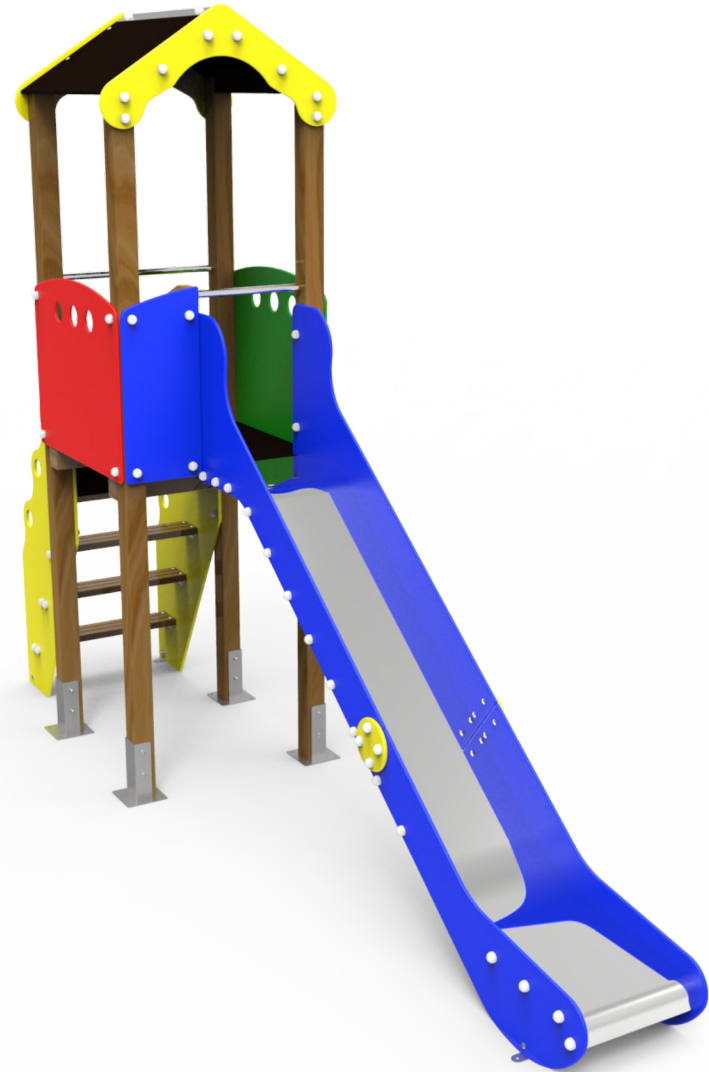

Ref.: MXT01

Maxi Torre “Segura”

UNE EN 1176-1:2018

UNE EN 1176-3:2018



Altura libre de caída: 1,36 m
Edad recomendada de uso: a partir de 3 años
Madera de pino tratada en autoclave Nivel IV
Componentes plásticos: Polietileno de alta densidad con protección UV
Componentes metálicos galvanizados
Tobogán con rampa de acero inoxidable
Tubos de barrera de acero inoxidable

ALZADO

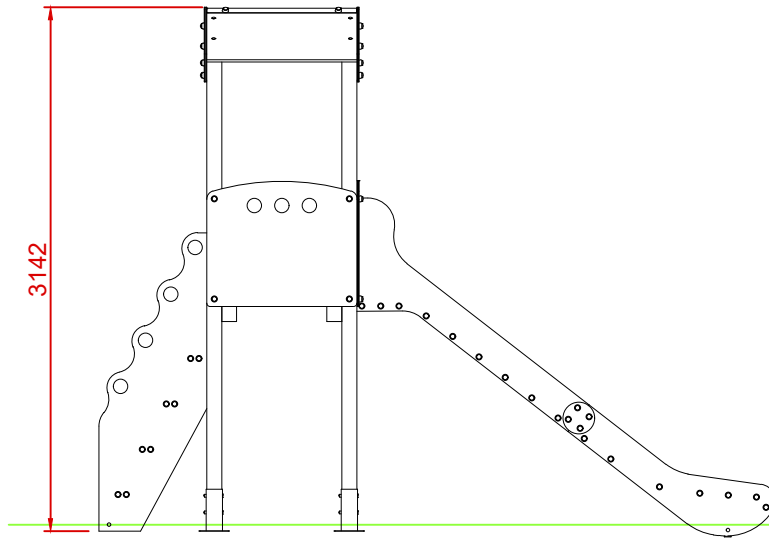

PERFIL

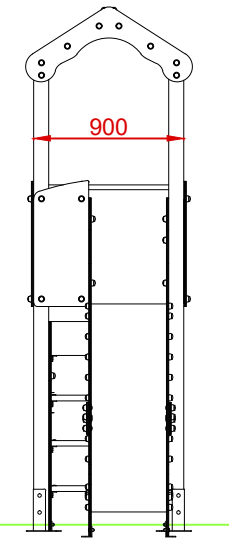

PLANTA

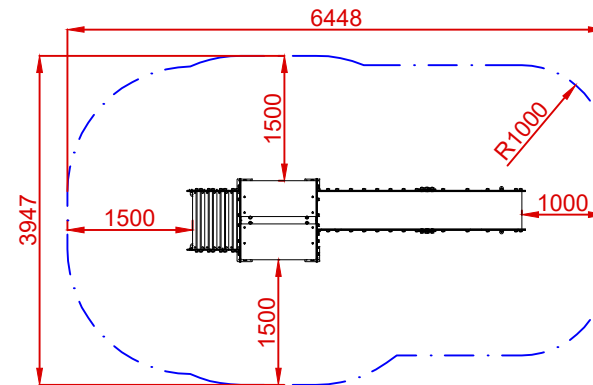
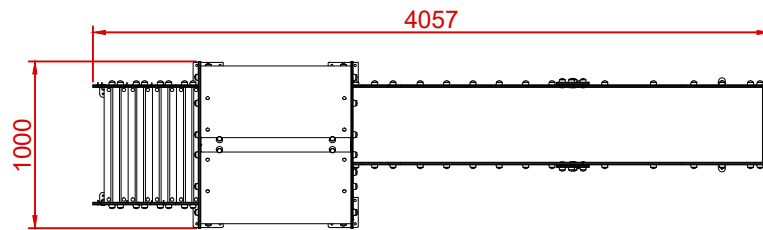

ÁREA DE SEGURIDAD
SUPERFICIE= 22,28 m²
E: 1/2

Dibujado		PLANO 1 VISTAS GENERALES	Ref:	MXT01
Revisado				
Aprobado				
Descripción:		Escala:	Nº Hoja:	
MAXI TORRE "SEGURA"			2/4	
		Fecha:	30/03/2020	

DETALLES CIMENTACIÓN

ESQUEMA DE CIMENTACIÓN EN ARENA

E: 2/1

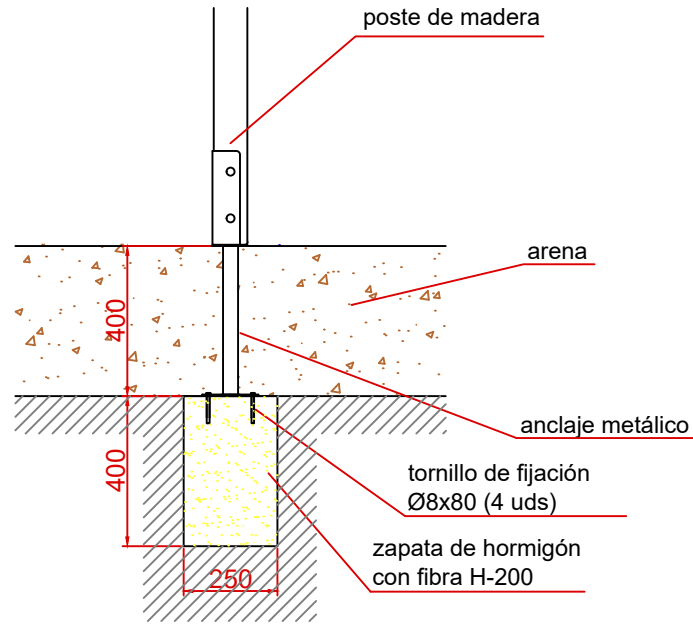

PLANTA CIMENTACIÓN

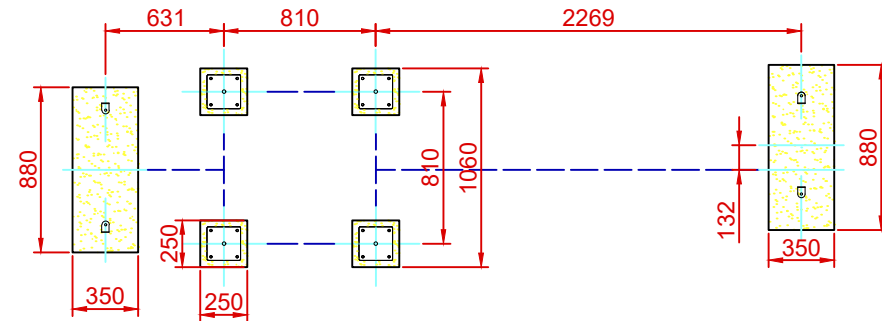

ESQUEMA DE CIMENTACIÓN EN HORMIGÓN

E: 2/1

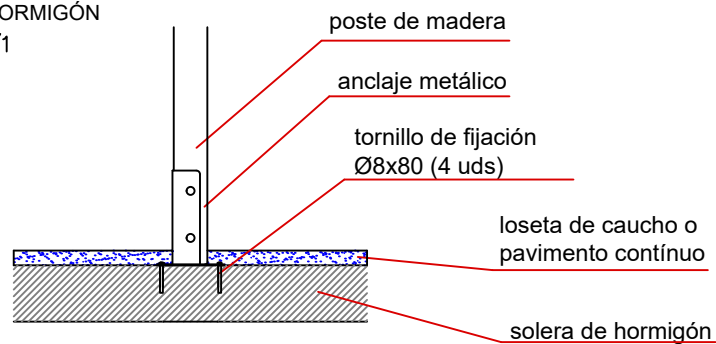

Dibujado		PLANO 2 CIMENTACIÓN Y ANCLAJES	Ref:	MXT01
Revisado			Escala:	Nº Hoja: 3/4
Aprobado				
Descripción:			MAXI TORRE "SEGURA"	



ALZADO

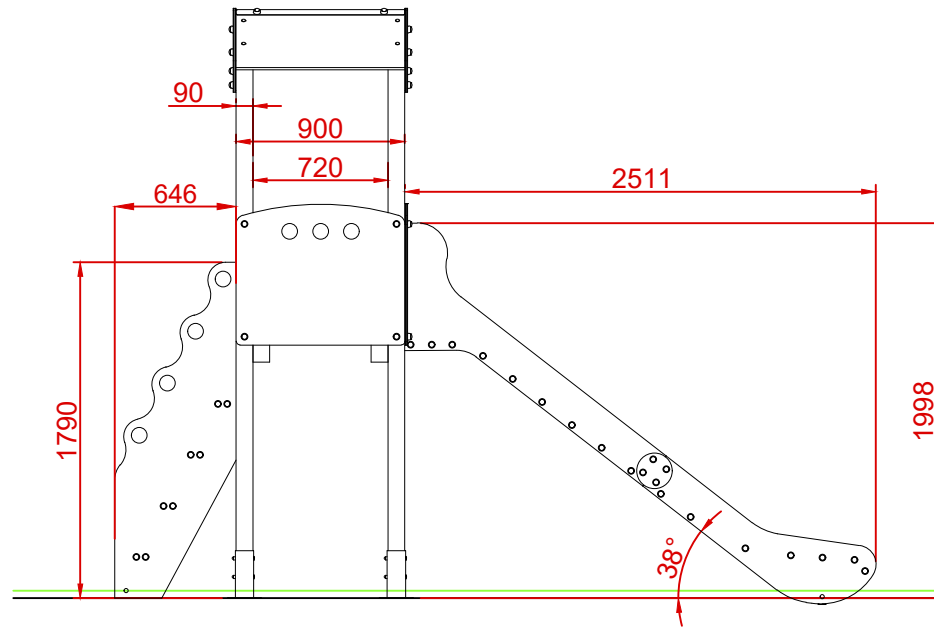

PERFIL

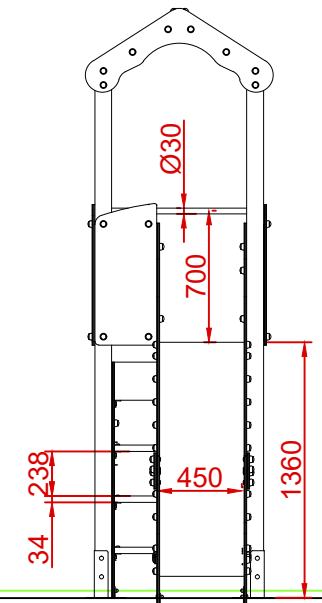

PLANTA

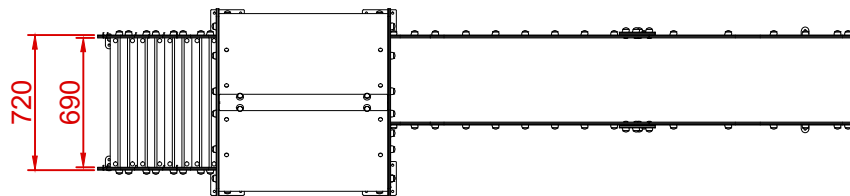

Dibujado		PLANO 3 DETALLES		Ref: MXT01
Revisado				
Aprobado				
Descripción:		Escala:	Nº Hoja:	
MAXI TORRE "SEGURA"			4/4	
		Fecha:	30/03/2020	