

DOCUMENTACIÓN TÉCNICA



Ref.: MXT02

Maxi Torre "Segre"

UNE EN 1176-1:2018

UNE EN 1176-3:2018

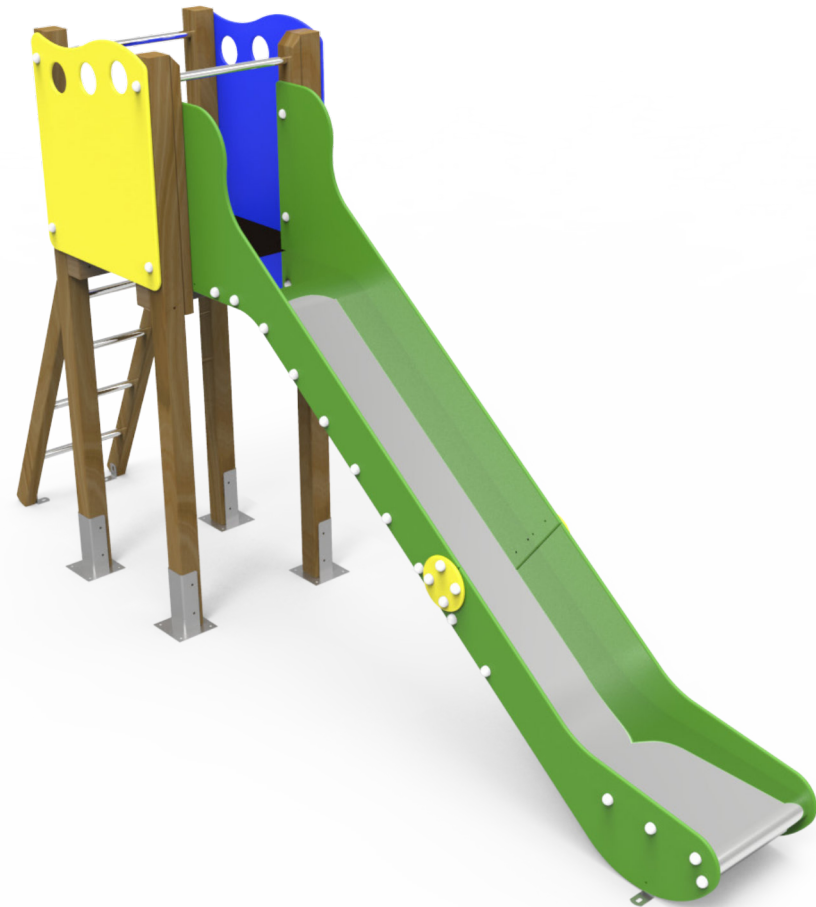

Altura libre de caída: 1,36 m
Edad recomendada de uso: a partir de 3 años
Madera de pino tratada en autoclave Nivel IV
Componentes plásticos: Polietileno de alta densidad con protección UV
Componentes metálicos galvanizados
Tobogán con rampa de acero inoxidable
Tubos de barrera de acero inoxidable

ALZADO

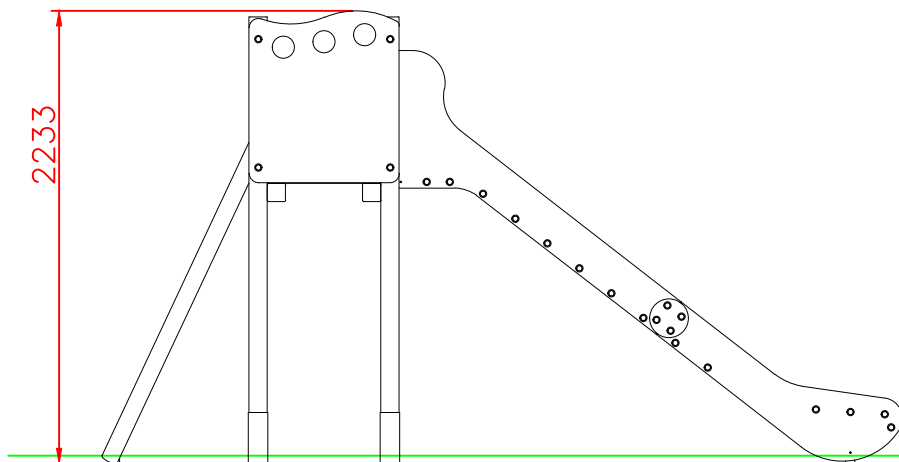

PERFIL

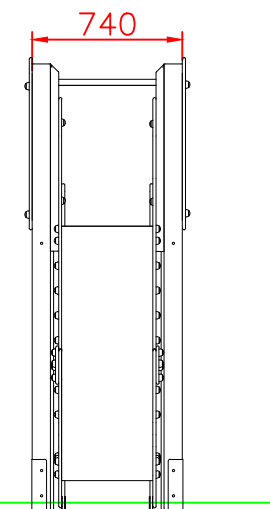

PLANTA

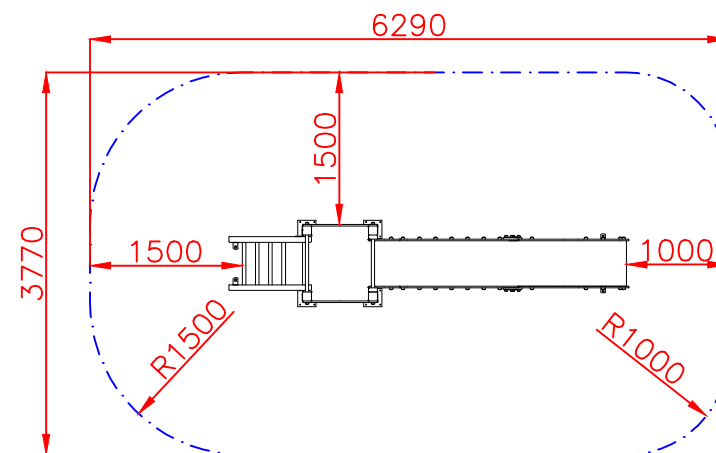
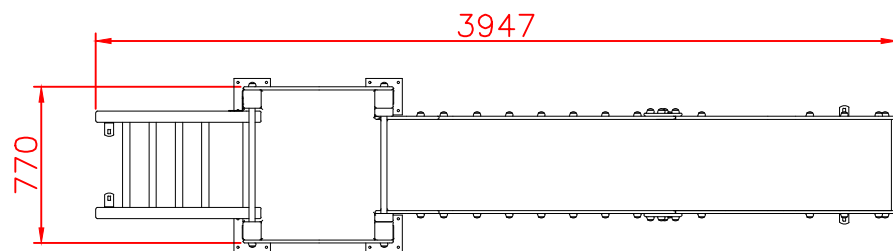

ÁREA DE SEGURIDAD
SUPERFICIE= 22,31 m²
E: 1/2

Dibujado		PLANO 1 VISTAS GENERALES		Ref:	MXT02
Revisado				Escala:	Nº Hoja: 2/4
Aprobado					
Descripción:			MAXI TORRE "SEGRE"		

DETALLES CIMENTACIÓN

ESQUEMA DE CIMENTACIÓN EN ARENA

E: 2/1

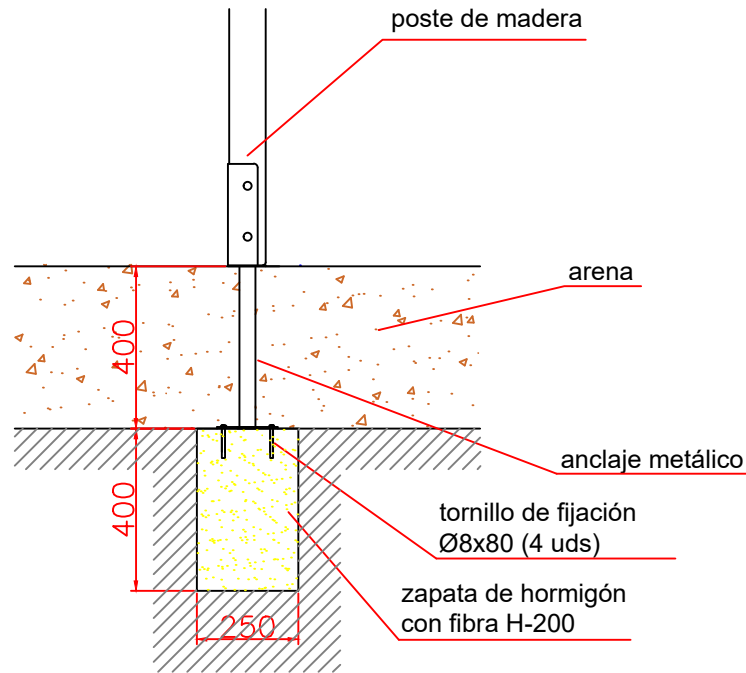

PLANTA CIMENTACIÓN

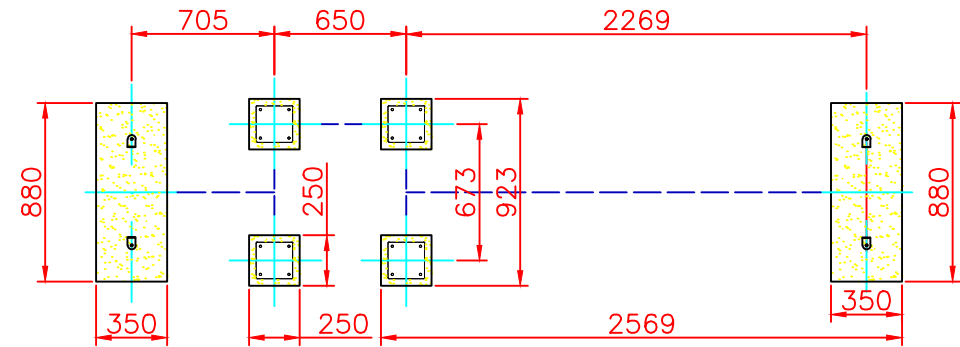

ESQUEMA DE CIMENTACIÓN EN HORMIGÓN

E: 2/1

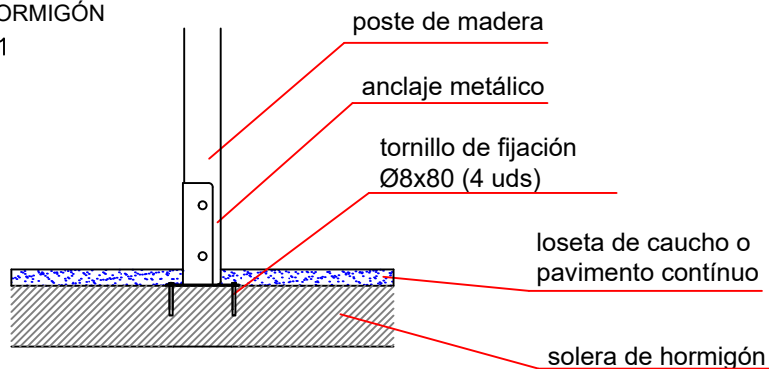

Dibujado		PLANO 2 CIMENTACIÓN Y ANCLAJES	Ref: MXT02
Revisado			
Aprobado			
Descripción:		Escala:	Nº Hoja:
MAXI TORRE "SEGRE"			3/4
		Fecha:	29-04-19



ALZADO

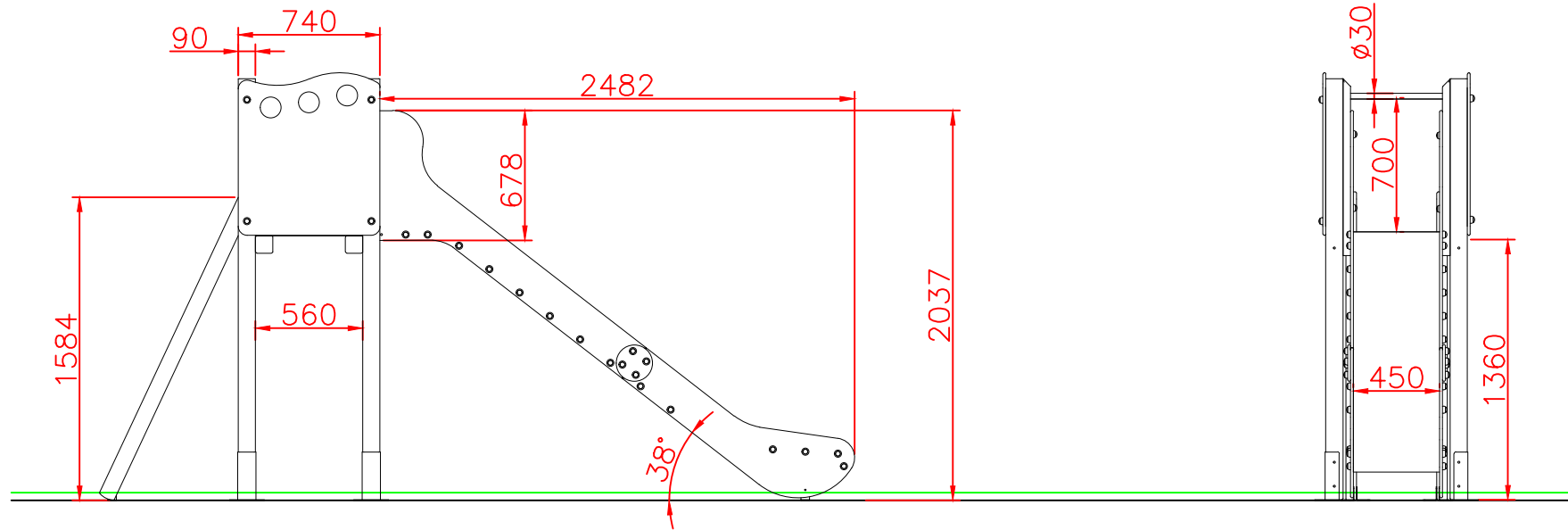

PERFIL

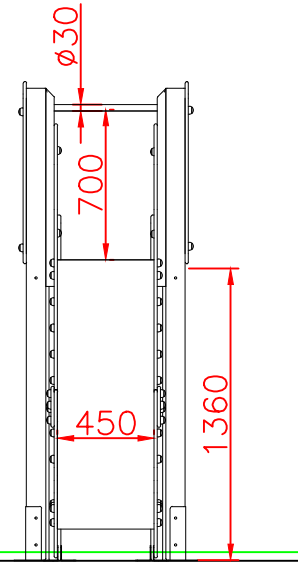

PLANTA

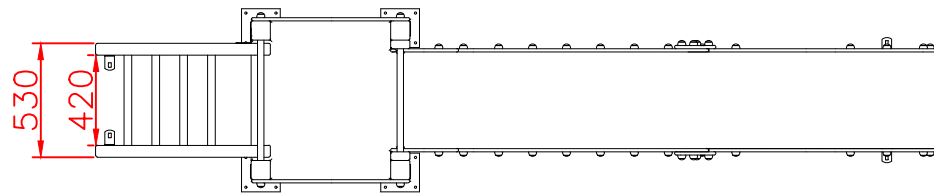

Dibujado		PLANO 3 DETALLES		Ref:	MXT02
Revisado					
Aprobado					
Descripción:			Escala:	Nº Hoja:	
MAXI TORRE "SEGRE"			Fecha:	4/4 29-04-19	