

# DOCUMENTACIÓN TÉCNICA



Ref.: MXT04

Maxi Torre "Júcar"

UNE EN 1176-1:2018

UNE EN 1176-3:2018



Altura libre de caída: 1,36 m

Edad recomendada de uso: a partir de 3 años

Madera de pino tratada en autoclave Nivel IV

Componentes plásticos: Polietileno de alta densidad con protección UV

Componentes metálicos galvanizados

Tobogán con rampa de acero inoxidable

Tubos de barrera de acero inoxidable

ALZADO

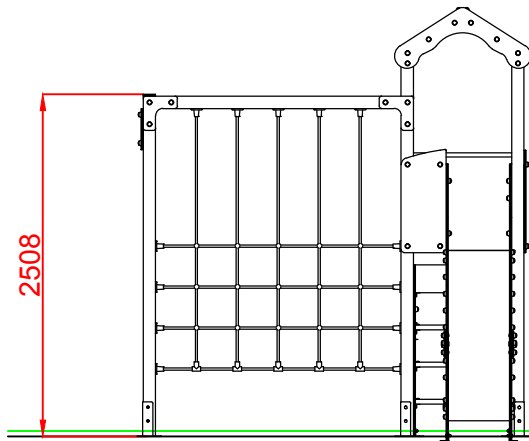

PERFIL

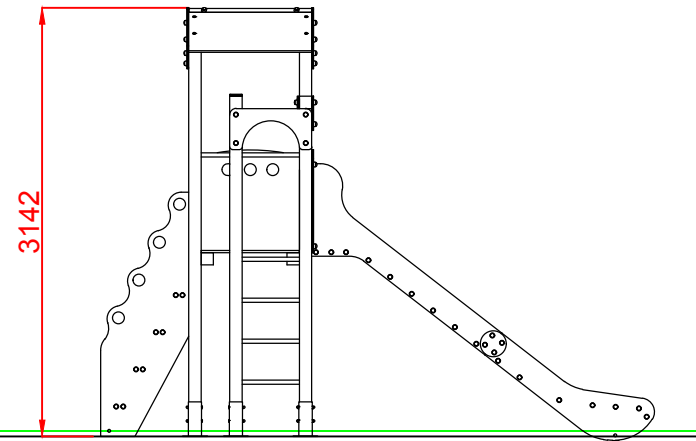

PLANTA

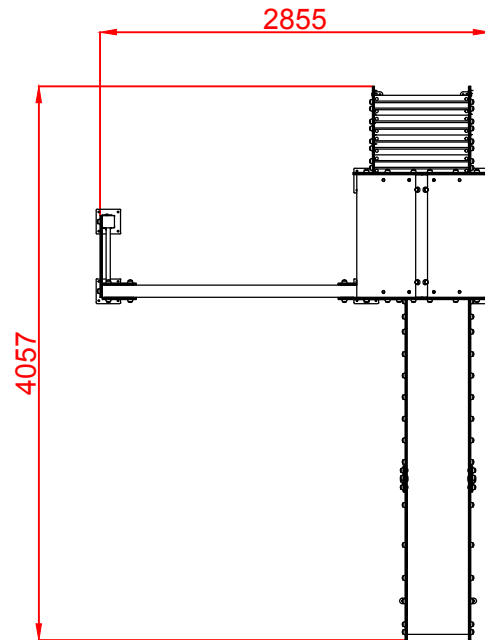

ÁREA DE SEGURIDAD  
SUPERFICIE= 28,5 m<sup>2</sup>  
E:1/2

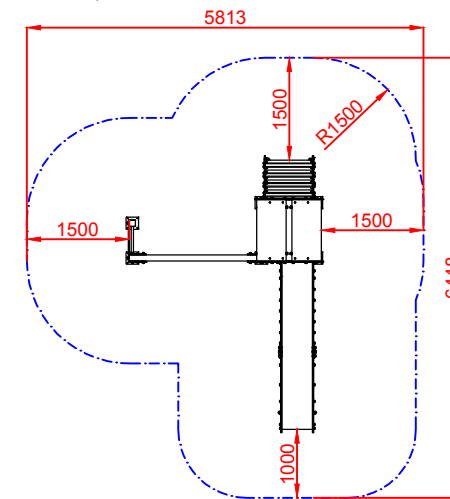

Dibujado		PLANO 1 VISTAS GENERALES	Ref:	MXT04
Revisado				
Aprobado				
Descripción:		MAXI TORRE "JÚCAR"	Escala:	Nº Hoja 2/4
			Fecha:	30/03/2020

# DETALLES CIMENTACIÓN

## ESQUEMA DE CIMENTACIÓN EN ARENA

E:2/1

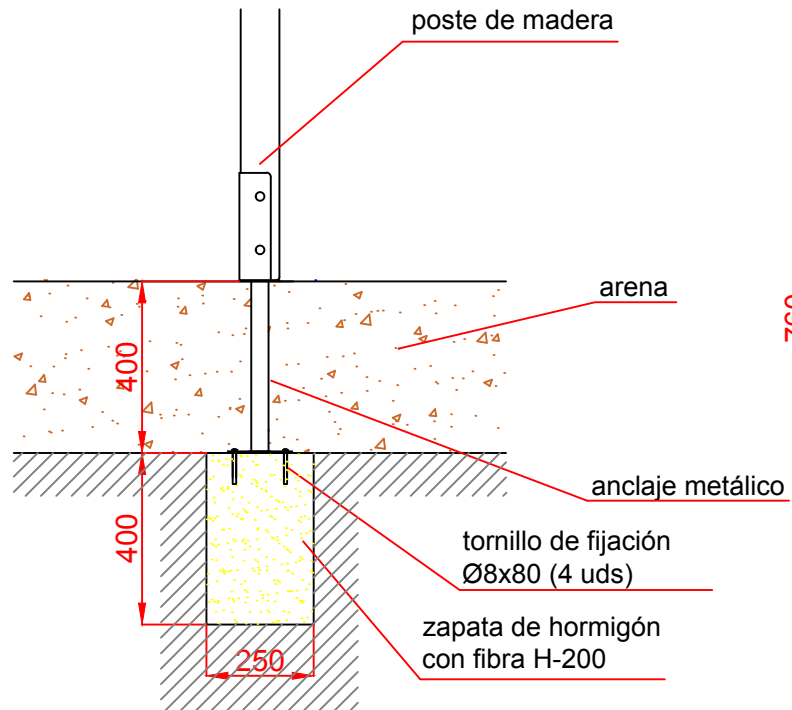

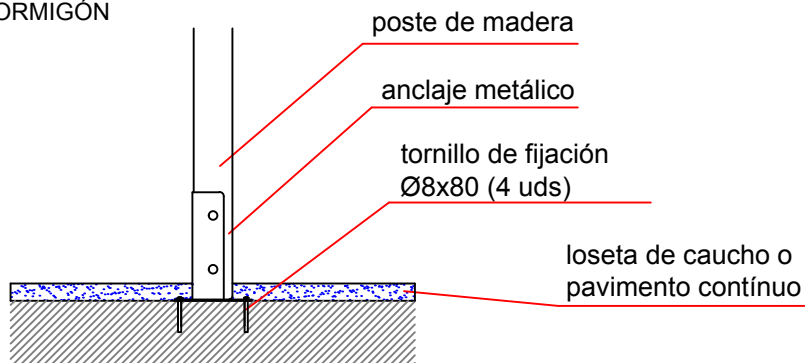

## ESQUEMA DE CIMENTACIÓN EN HORMIGÓN

E:2/1

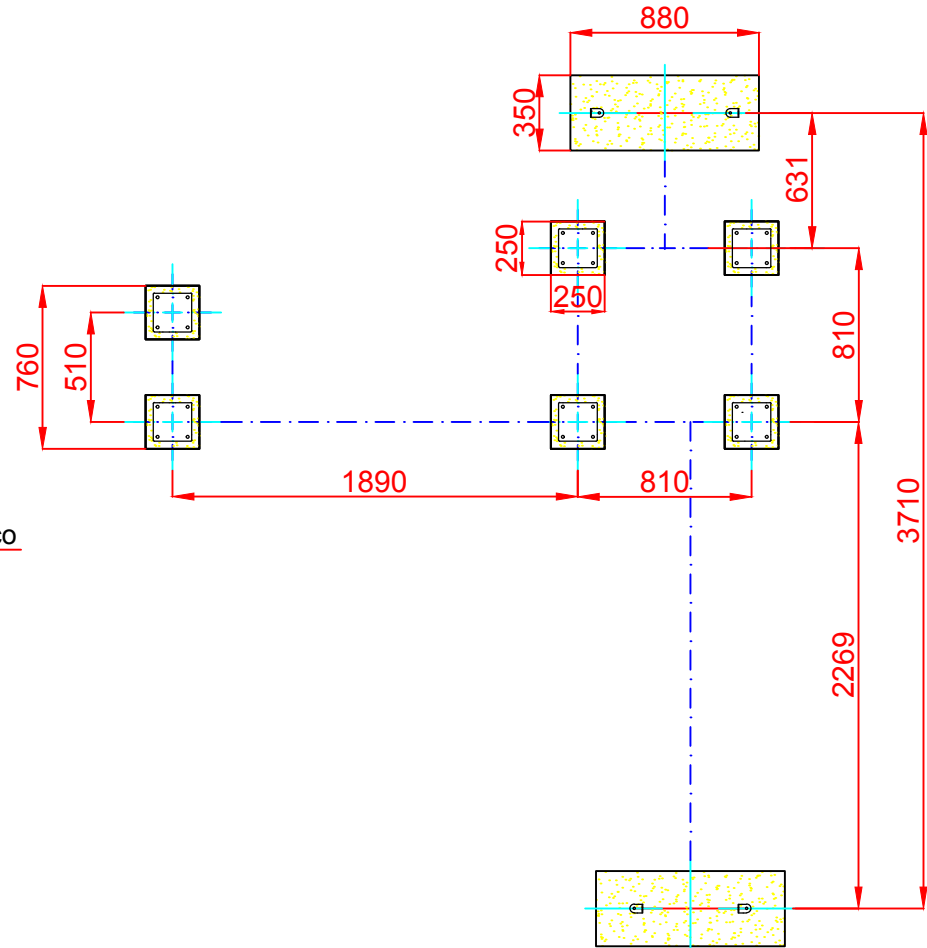

## PLANTA CIMENTACIÓN



Dibujado		PLANO 2 CIMENTACIÓN Y ANCLAJES	Ref:	MXT04
Revisado			Escala:	Nº Hoja 3/4
Aprobado				
Descripción:		MAXI TORRE "JÚCAR"		

ALZADO

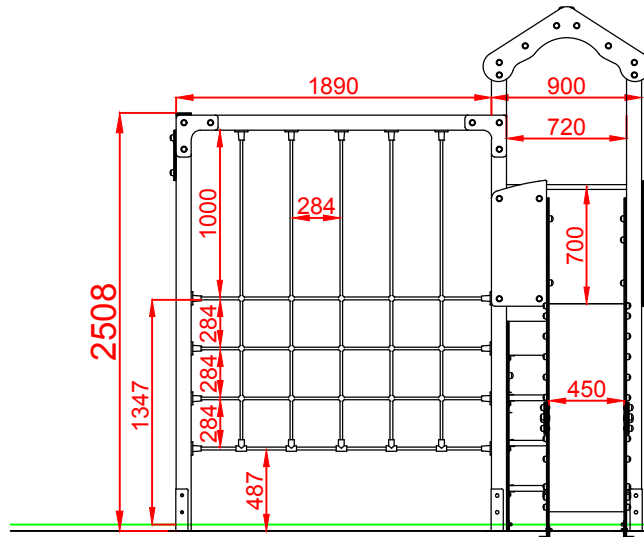

PERFIL

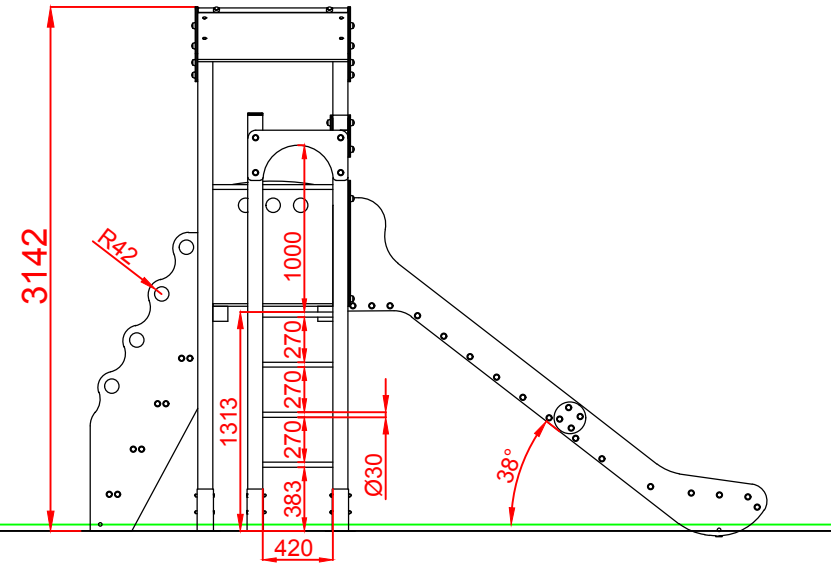

PLANTA

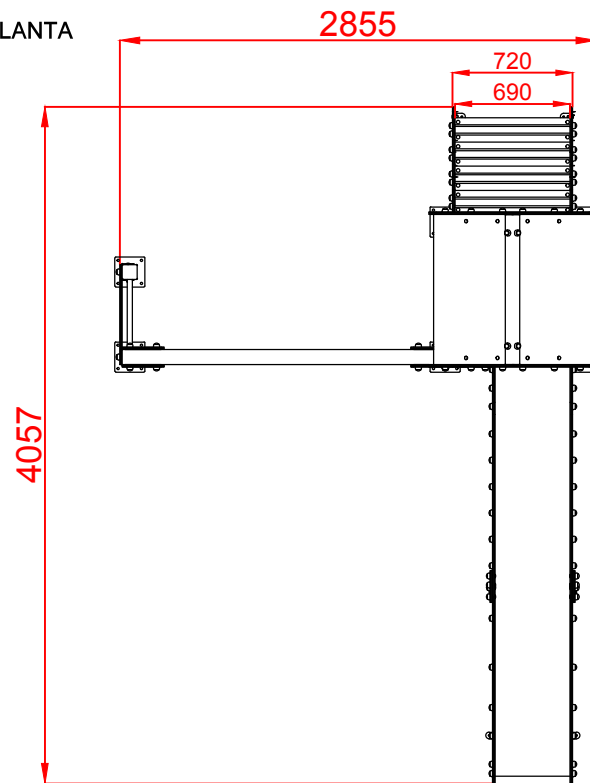

Dibujado		PLANO 3 VISTAS DE DETALLE		Ref: MXT04
Revisado				
Aprobado				
Descripción:		MAXI TORRE "JÚCAR"	Escala: N° Hoja 4/4	Fecha: 30/03/2020