

DOCUMENTACIÓN TÉCNICA



Ref.: MXT08

Maxi Torre "Tajo"

UNE EN 1176-1:2018

UNE EN 1176-3:2018



Altura libre de caída: 1,36 m

Edad recomendada de uso: a partir de 3 años

Madera de pino tratada en autoclave Nivel IV

Componentes plásticos: Polietileno de alta densidad con protección UV

Componentes metálicos galvanizados

Tobogán con rampa de acero inoxidable

Tubos de barrera de acero inoxidable

ALZADO

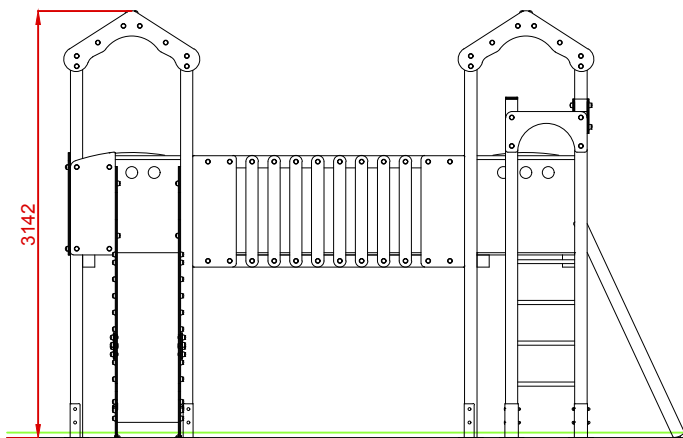

PERFIL IZQUIERDO

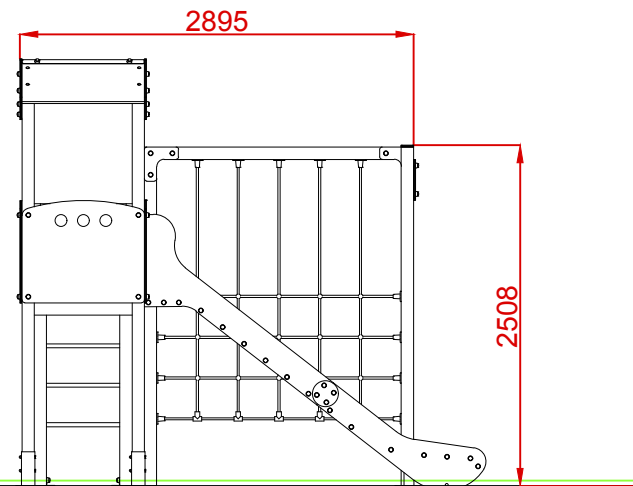

PLANTA

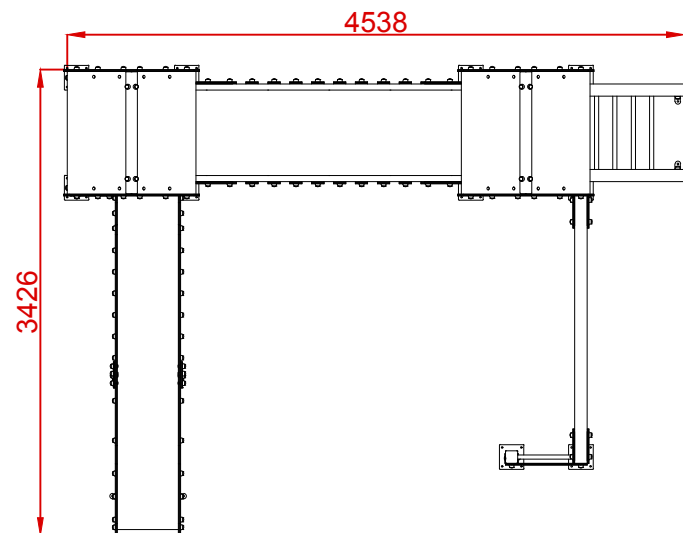

ÁREA DE SEGURIDAD

ÁREA= 38,67 m²

E: 1/2

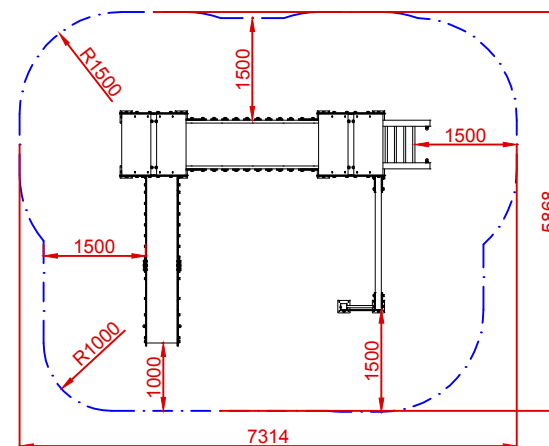

Dibujado		PLANO 1 VISTAS GENERALES		Ref: MXT08
Revisado				
Aprobado				
Descripción:		MAXI TORRE "TAJO"	Escala: N° Hoja 2/4	Fecha: 02/04/2020

DETALLES CIMENTACIÓN

ESQUEMA DE CIMENTACIÓN EN ARENA E: 2/1

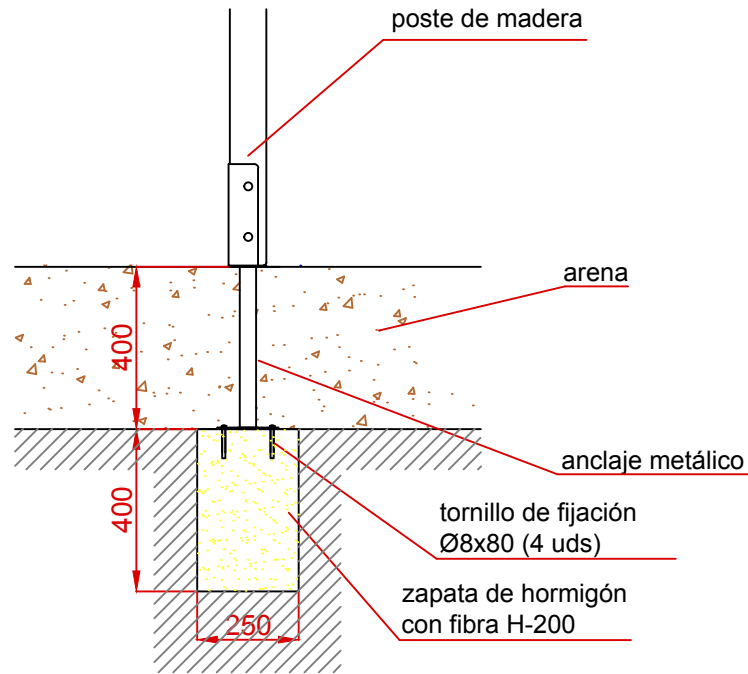

ESQUEMA DE CIMENTACIÓN EN HORMIGÓN E: 2/1

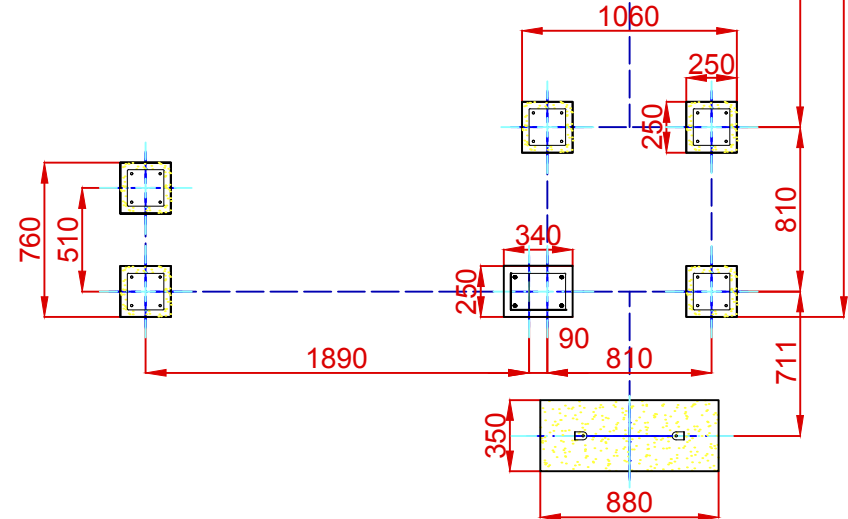
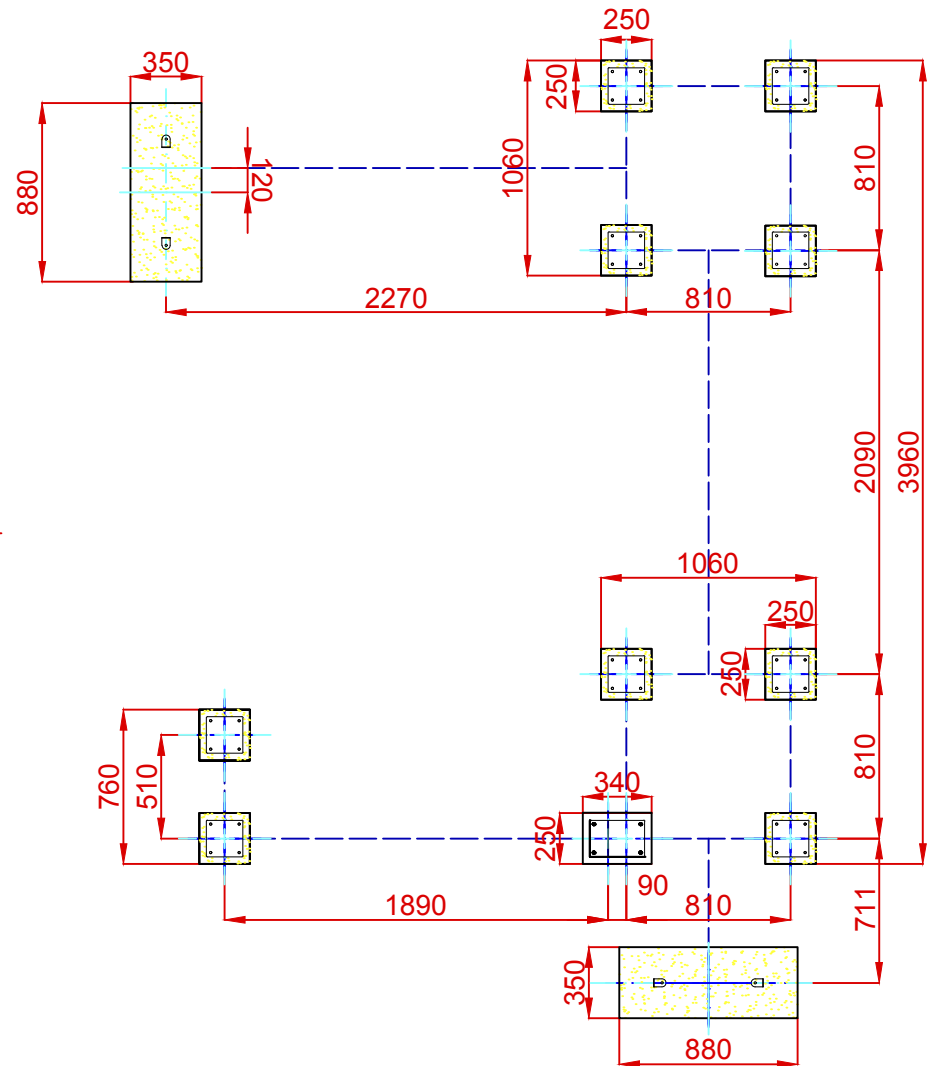
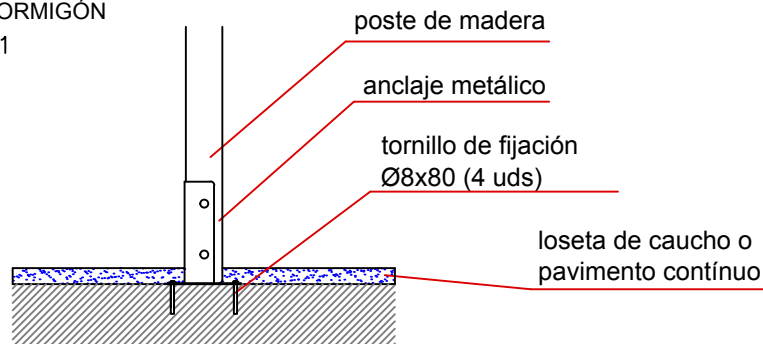

Dibujado		PLANO 2 CIMENTACIÓN Y ANCLAJES		Ref: MXT08
Revisado				
Aprobado				
Descripción: MAXI TORRE "TAJO"		Escala:	Nº Hoja 3/4	
		Fecha: 02/04/2020		

ALZADO

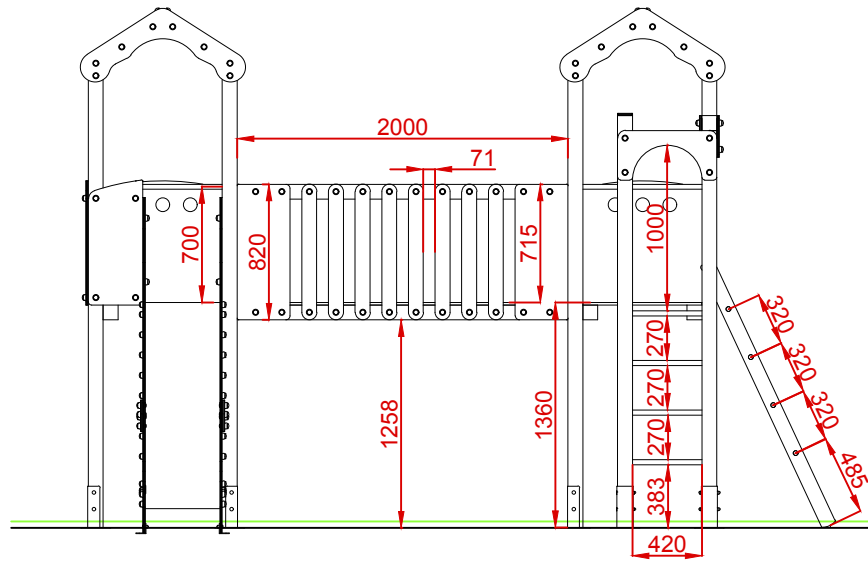

PERFIL IZQUIERDO

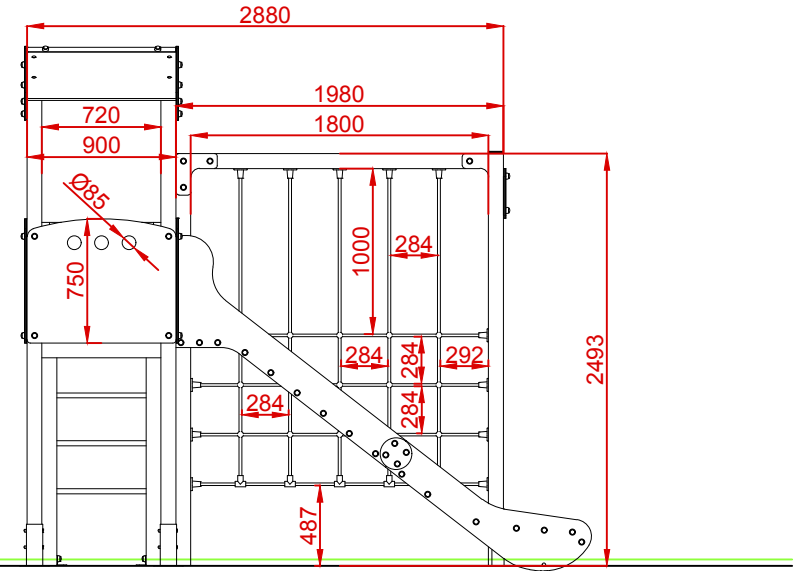

PLANTA

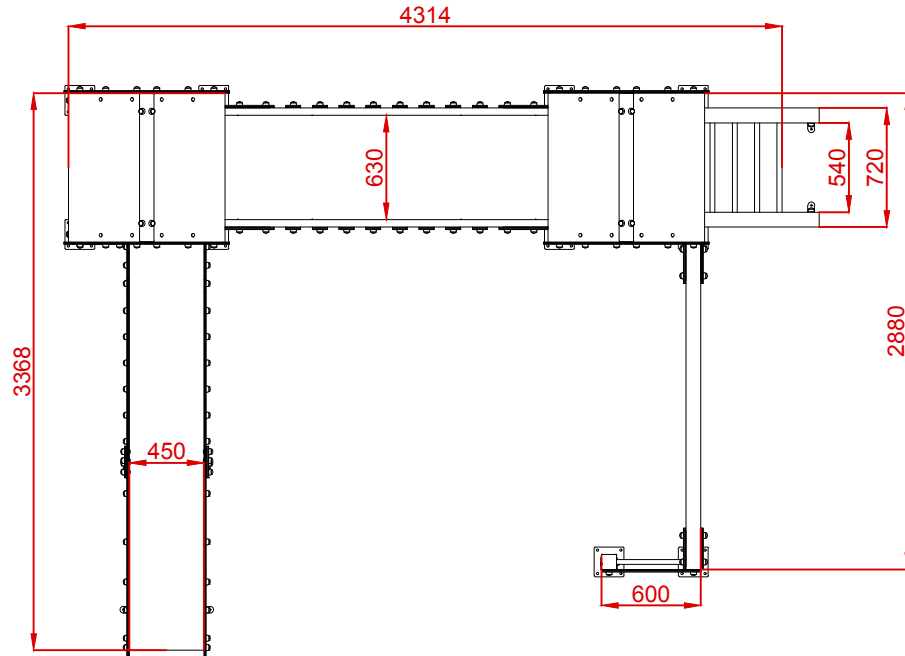

Dibujado		PLANO 3 VISTAS DE DETALLE	Ref:	MXT08
Revisado				
Aprobado				
Descripción:		MAXI TORRE "TAJO"	Escala:	Nº Hoja 4/4
			Fecha:	02/04/2020