

DOCUMENTACIÓN TÉCNICA



Ref.: MXT14

Maxi Torre "Nalón"

UNE EN 1176-1:2018

UNE EN 1176-3:2018



Altura libre de caída: 1,36 m

Edad recomendada de uso: a partir de 3 años

Madera de pino tratada en autoclave Nivel IV

Componentes plásticos: Polietileno de alta densidad con protección UV

Componentes metálicos galvanizados

Tobogán con rampa de acero inoxidable

Tubos de barrera de acero inoxidable

ALZADO

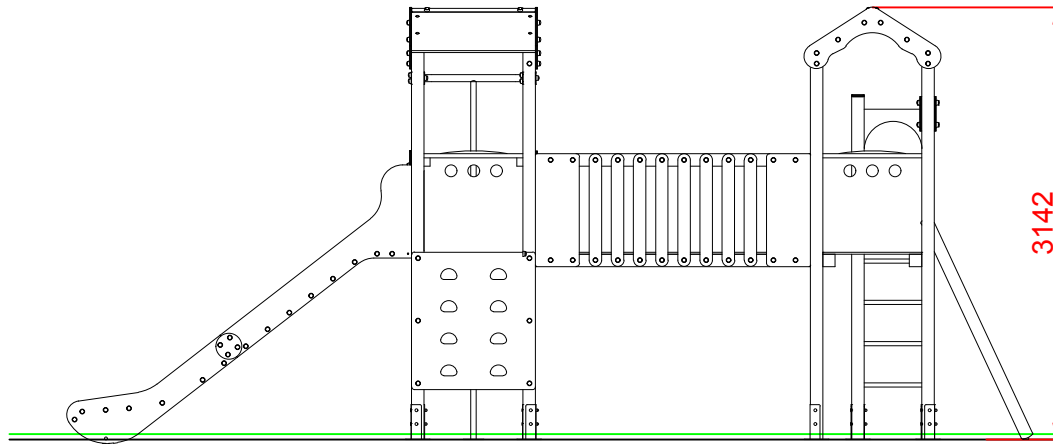

PERFIL

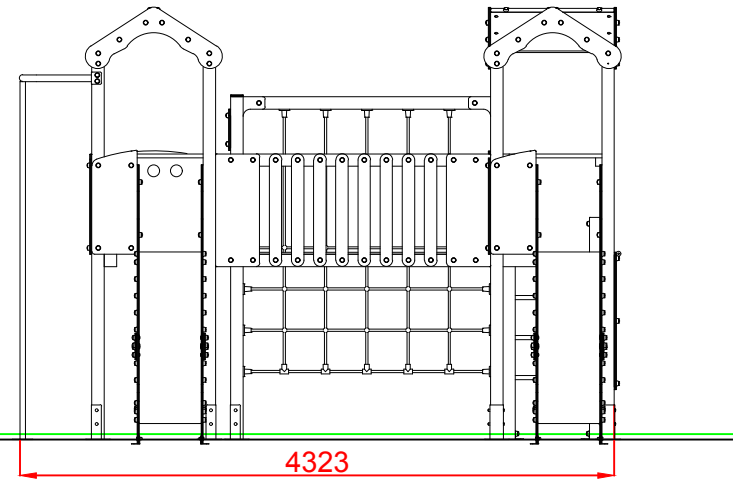

PLANTA

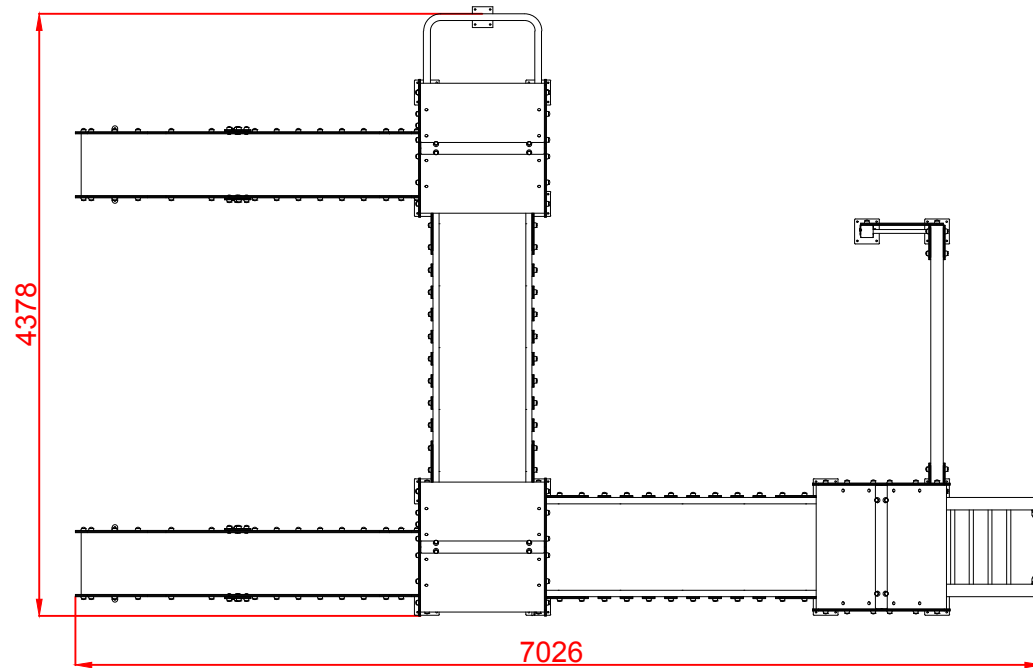

ÁREA DE SEGURIDAD
SUPERFICIE= 53,38 m2
E:1/2

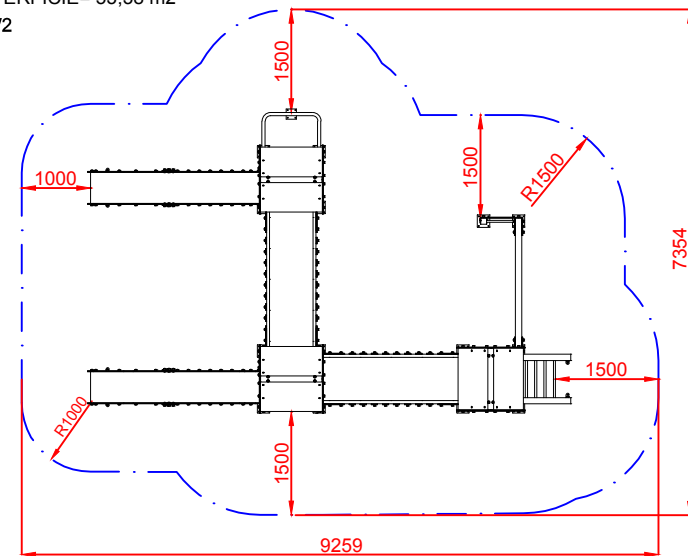

Dibujado		PLANO 1 VISTAS GENERALES		Ref: MXT14	
Revisado					
Aprobado		Descripción:	Escala:		Nº Hoja 2/4
		MAXI TORRE "NALÓN"	Fecha:		03/04/2020

DETALLES CIMENTACIÓN

ESQUEMA DE CIMENTACIÓN
EN ARENA

E:2/1

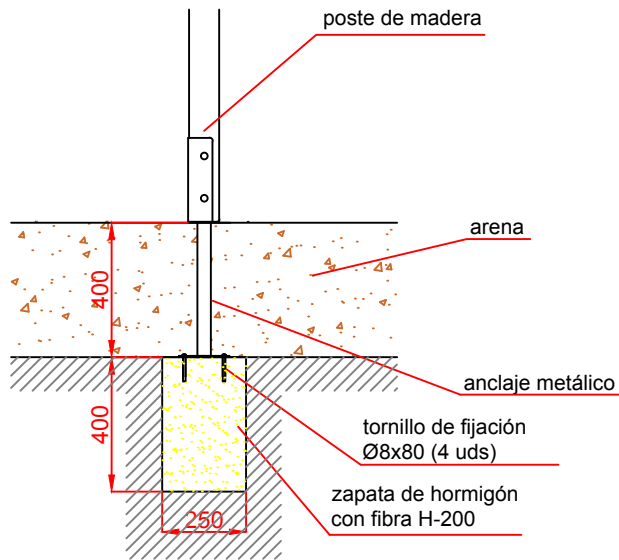

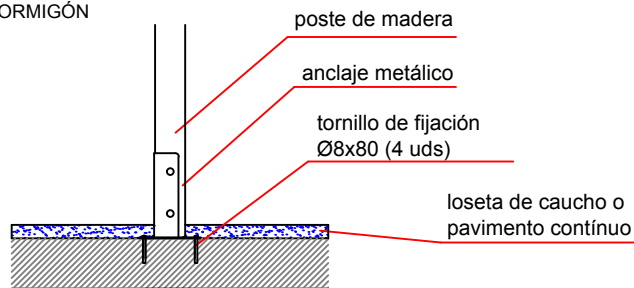

ESQUEMA DE CIMENTACIÓN
EN HORMIGÓN

E:2/1

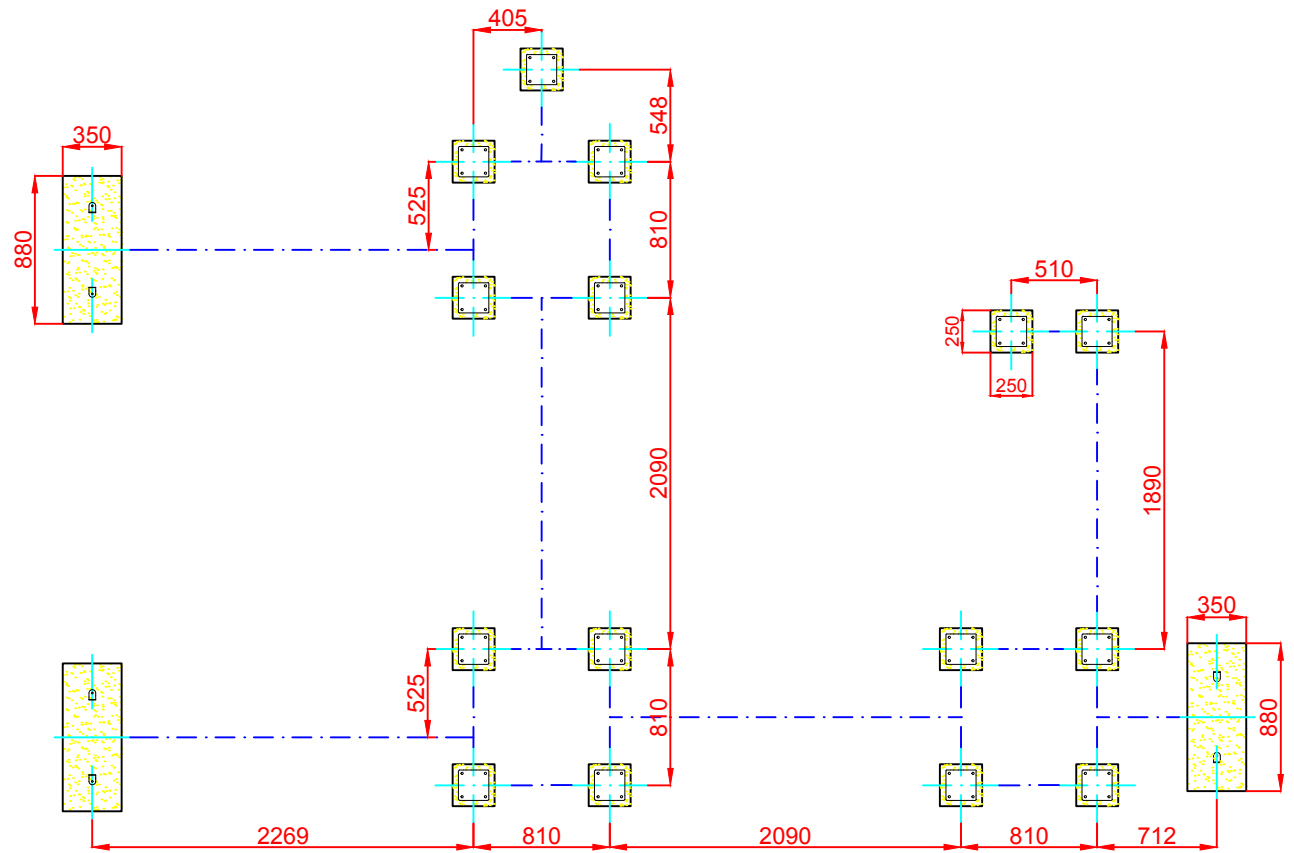

PLANTA CIMENTACIÓN



Dibujado		PLANO 2 CIMENTACIÓN Y ANCLAJES		Ref: MXT14
Revisado				
Aprobado		Descripción: MAXI TORRE "NALÓN"		
		Escala:	Nº Hoja 3/4	
		Fecha: 03/04/2020		

ALZADO

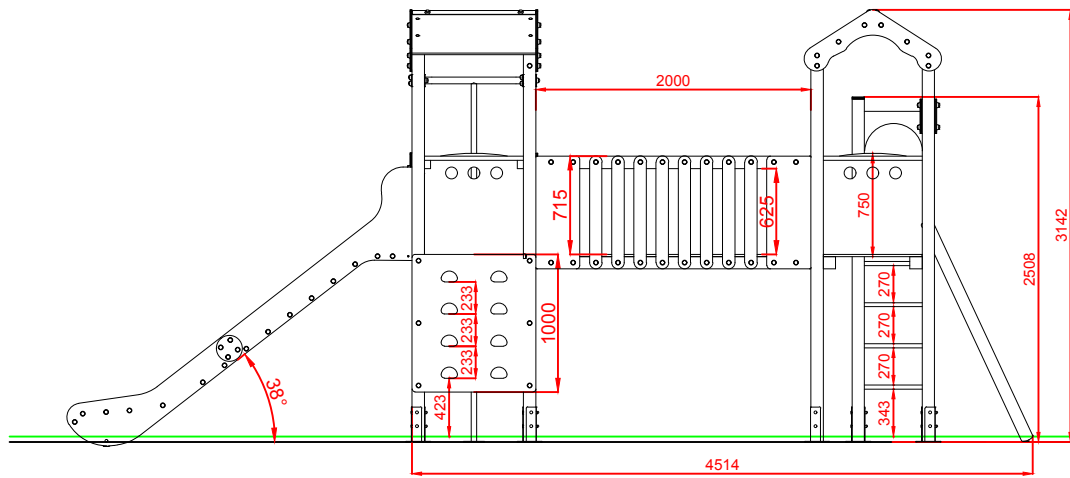

PERFIL

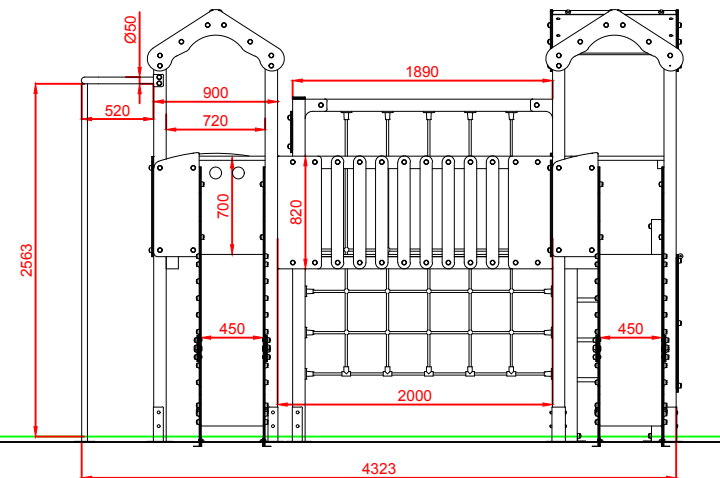

PLANTA

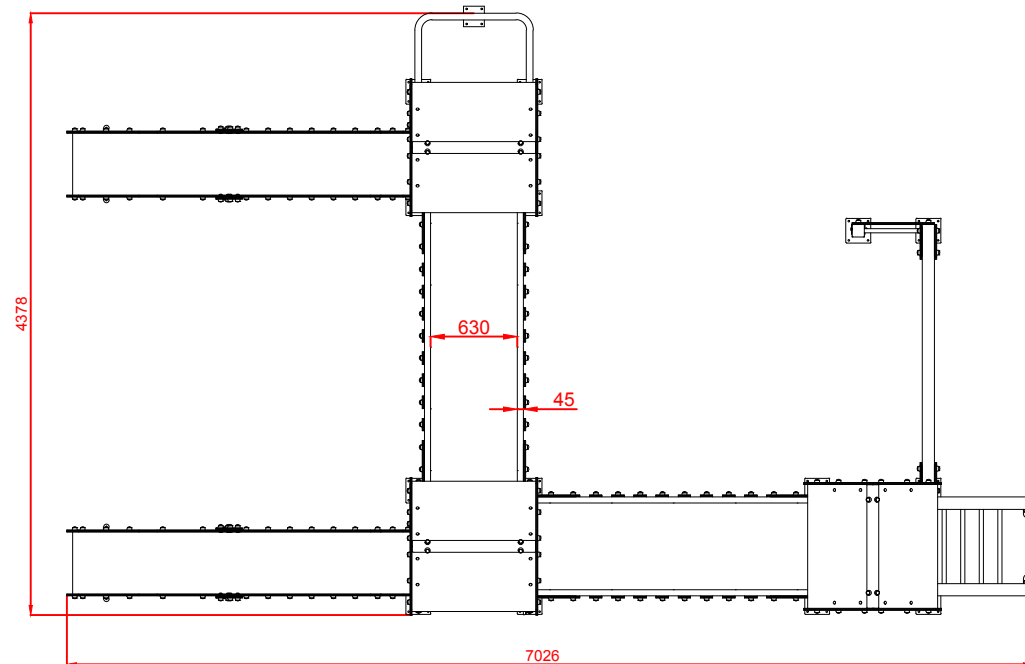

Dibujado		PLANO 3 VISTAS DE DETALLE		Ref: MXT14
Revisado				
Aprobado				
Descripción:		MAXI TORRE "NALÓN"	Escala:	Nº Hoja 4/4
			Fecha:	03/04/2020