

# DOCUMENTACIÓN TÉCNICA



Ref.: MXT17

Maxi Torre "Sil"

UNE EN 1176-1:2018

UNE EN 1176-3:2018



Altura libre de caída: 1,36 m  
Edad recomendada de uso: a partir de 3 años  
Madera de pino tratada en autoclave Nivel IV  
Componentes plásticos: Polietileno de alta densidad con protección UV  
Componentes metálicos galvanizados  
Tobogán con rampa de acero inoxidable  
Tubos de barrera de acero inoxidable

ALZADO

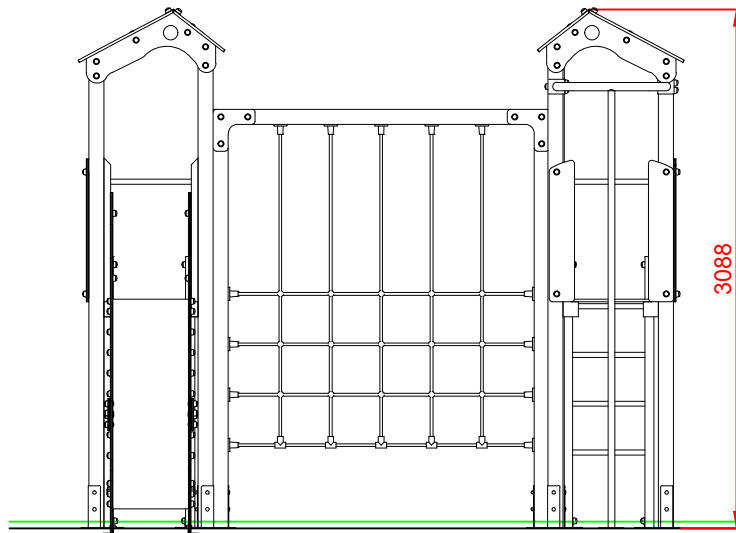

PERFIL IZQUIERDO

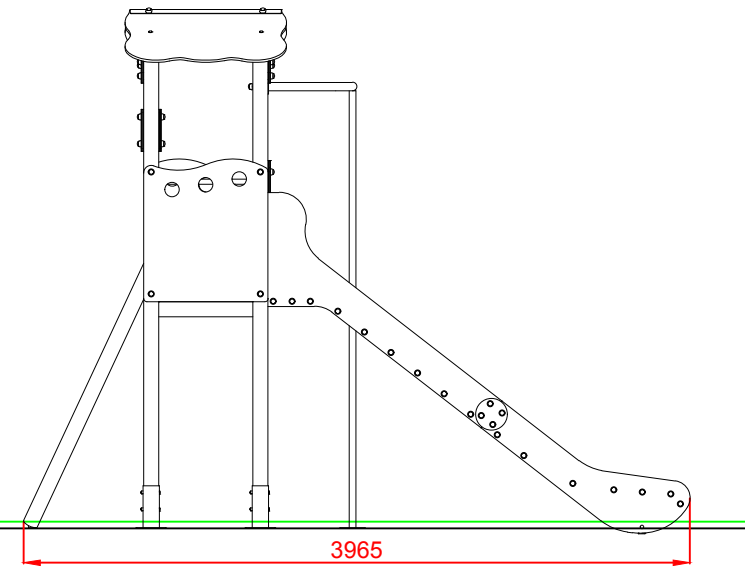

PLANTA

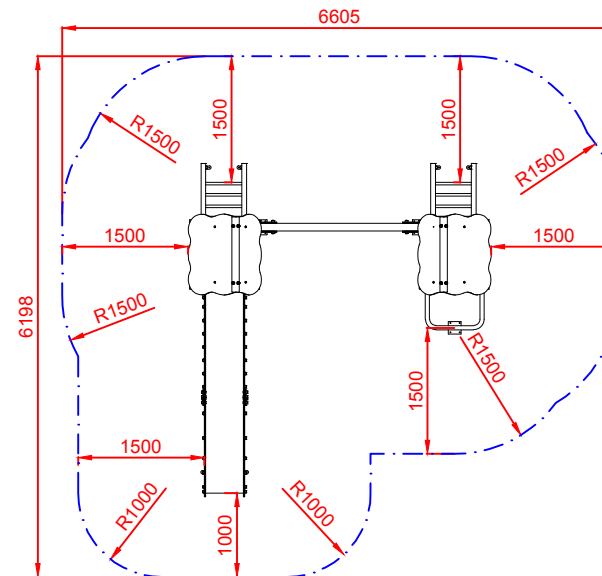
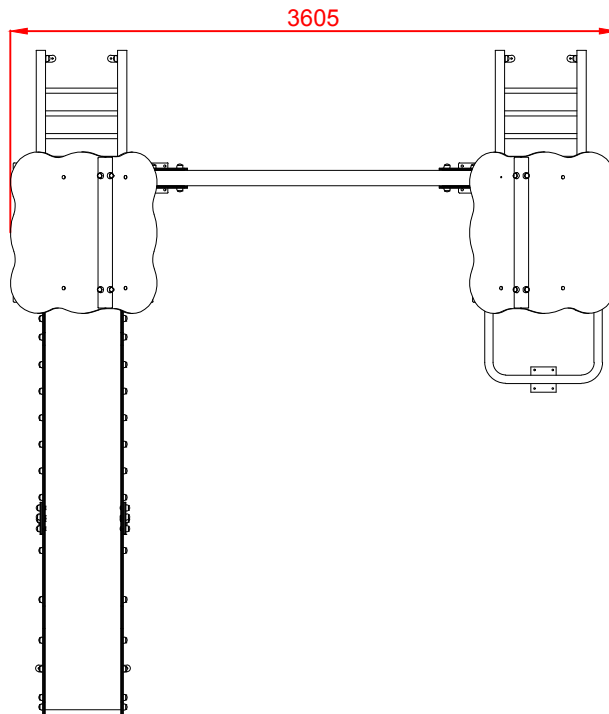

ÁREA DE SEGURIDAD  
Superficie= 33,19 m2  
E:1/2

Dibujado		PLANO 1 VISTAS GENERALES		Ref: MXT17	
Revisado					
Aprobado		Descripción:	Escala:		Nº Hoja 2/4
		MAXI TORRE "SIL"	Fecha:		06/04/2020

# DETALLES CIMENTACIÓN

## ESQUEMA DE CIMENTACIÓN EN ARENA E:2/1

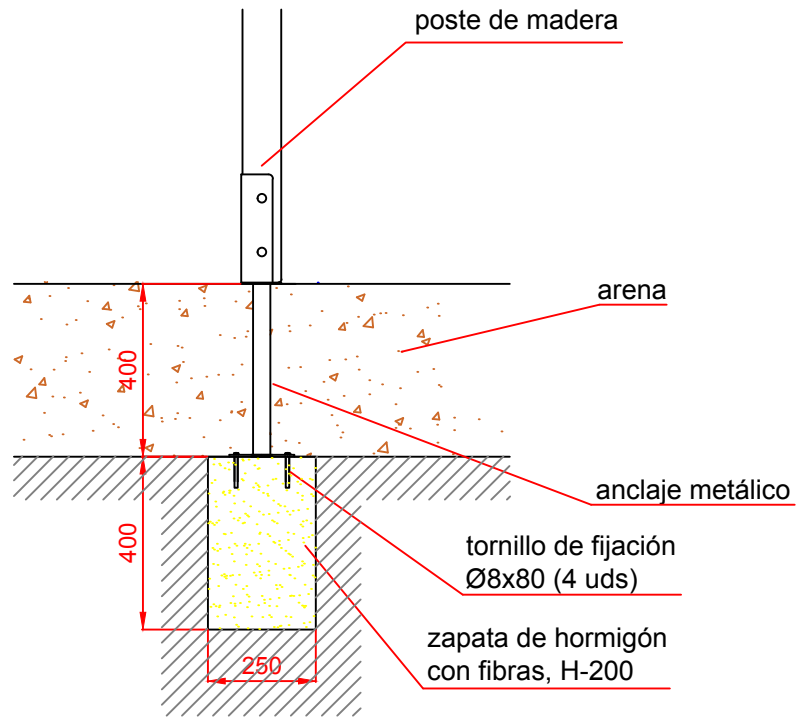

## ESQUEMA DE CIMENTACIÓN EN HORMIGÓN E:2/1

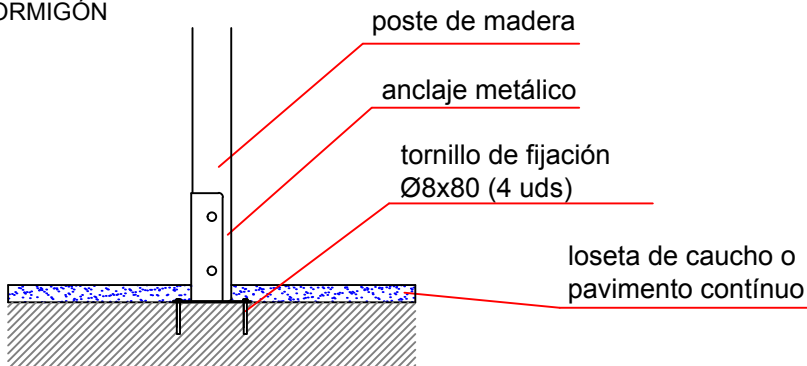

## PLANTA CIMENTACIÓN

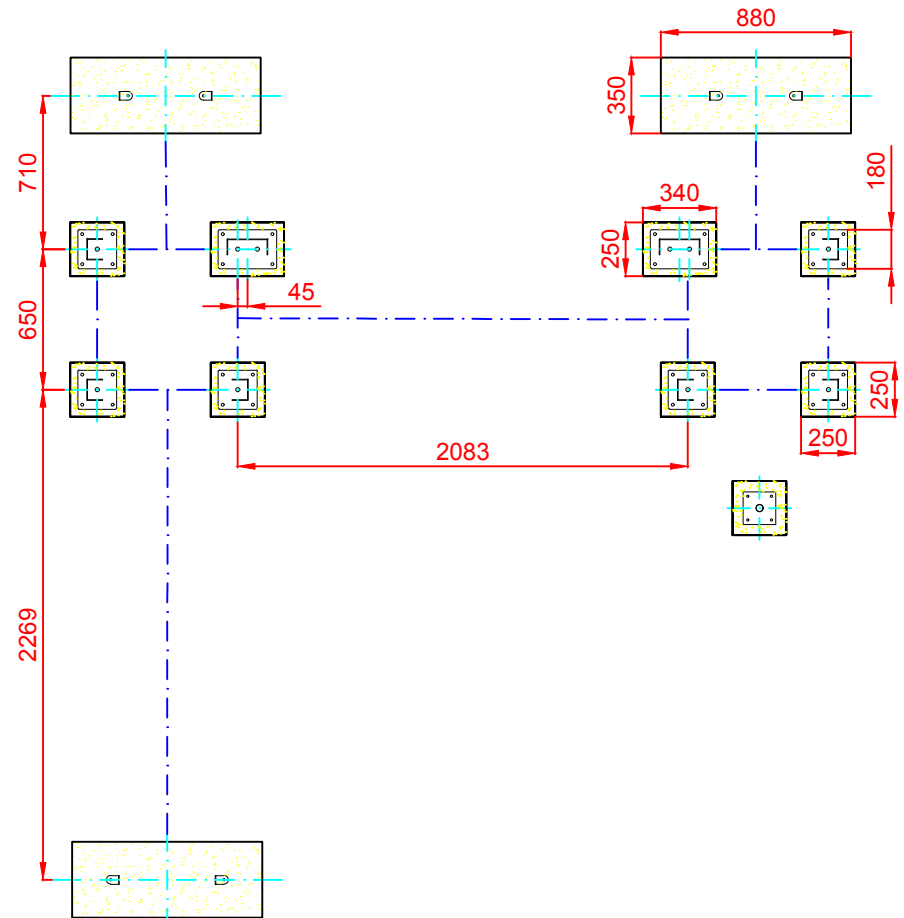

Dibujado		PLANO 2 CIMENTACIÓN Y ANCLAJES		Ref: MXT17
Revisado				
Aprobado				
Descripción: MAXI TORRE "SIL"		Escala:	Nº Hoja 3/4	
		Fecha: 06/04/2020		

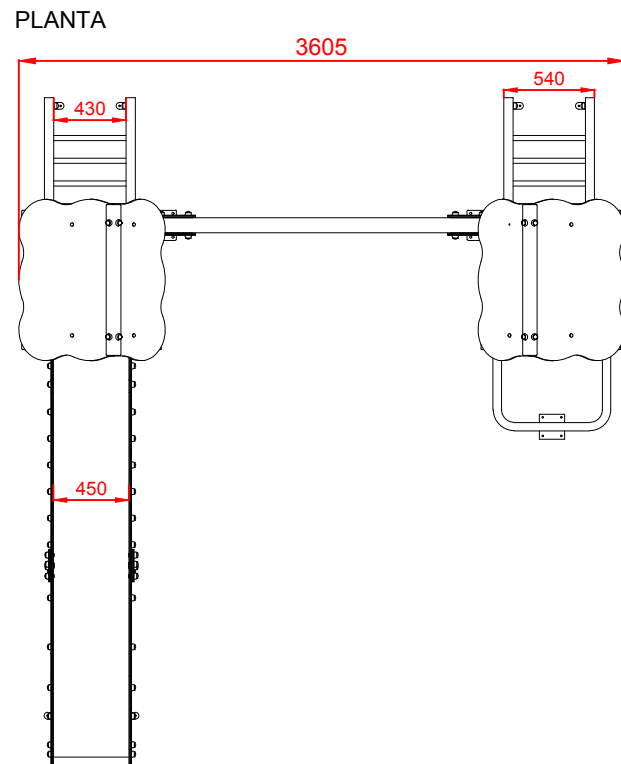
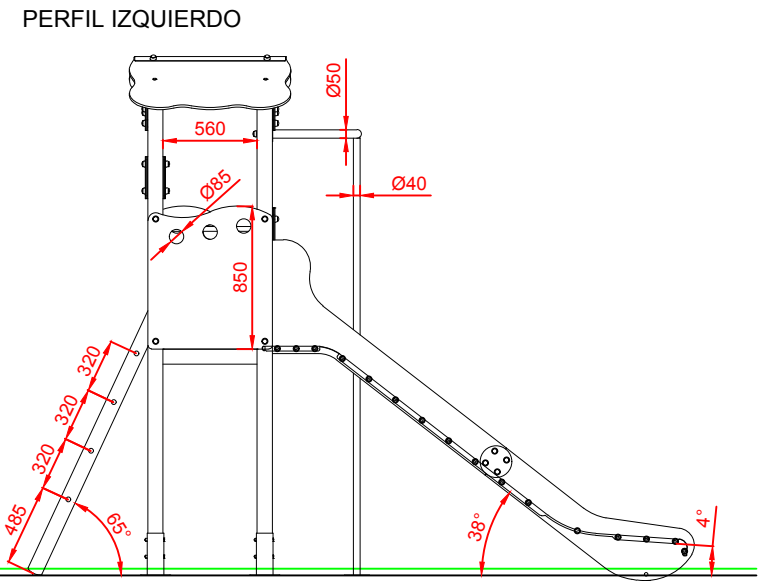
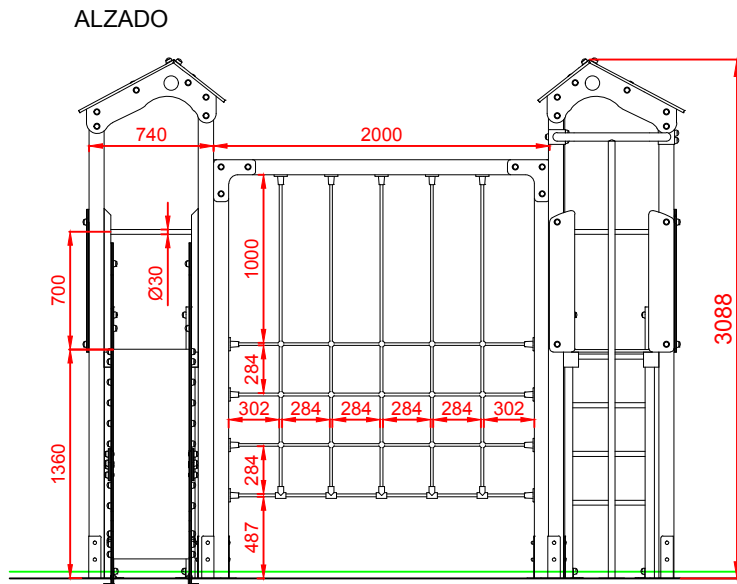

Dibujado		PLANO 3 VISTAS DE DETALLE		Ref: MXT17	
Revisado					
Aprobado		Descripción:	Escala:		Nº Hoja 4/4
		MAXI TORRE "SIL"	Fecha:		06/04/2020