

# DOCUMENTACIÓN TÉCNICA

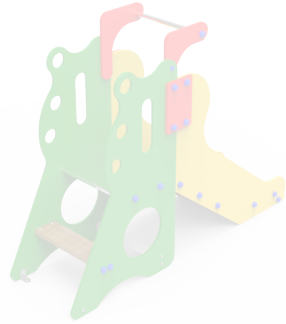

Ref.: TBG03

Tobogán "Cúber"

UNE-EN 1176 -1:2018

UNE-EN 1176 -3:2018



Altura libre de caída: 0,6 m

Edad recomendada de uso: a partir de 1 año

Componentes plásticos: Polietileno de alta densidad con protección UV

Rampa de tobogán: acero inoxidable

Tubo superior: acero inoxidable

Tornillería protegida con tapones de polipropileno

Madera de pino tratada en autoclave Nivel IV

ALZADO

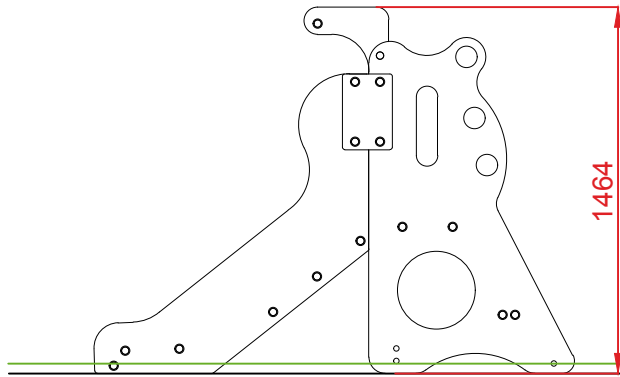

PERFIL

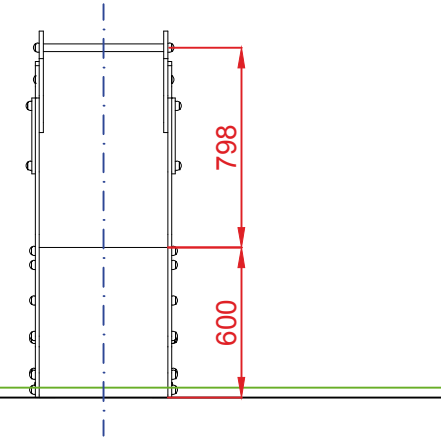

PLANTA

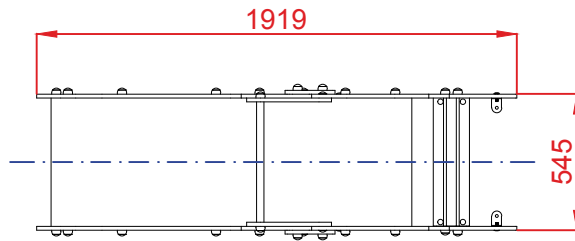

ÁREA DE SEGURIDAD  
Superficie= 13,52 m<sup>2</sup>  
E: 1/2

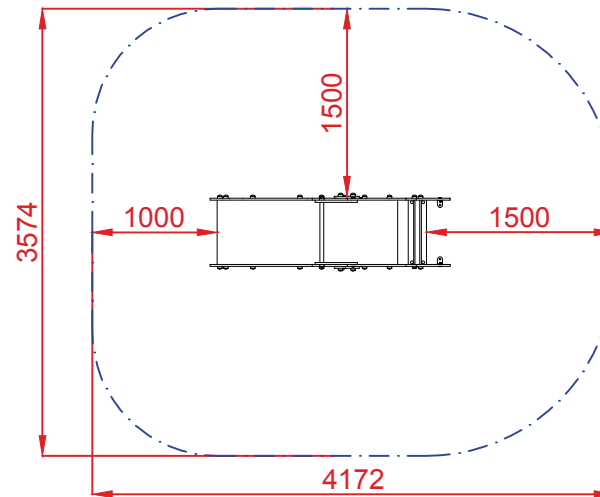

Dibujado		PLANO 1 VISTAS GENERALES	Ref:	TBG03
Revisado				
Aprobado				
Descripción:		TOBOGÁN "CÚBER"	Escala:	Nº Hoja 2/4
			Fecha:	08/08/2019

# DETALLES CIMENTACIÓN

ESQUEMA DE CIMENTACIÓN  
EN ARENA  
E: 2/1

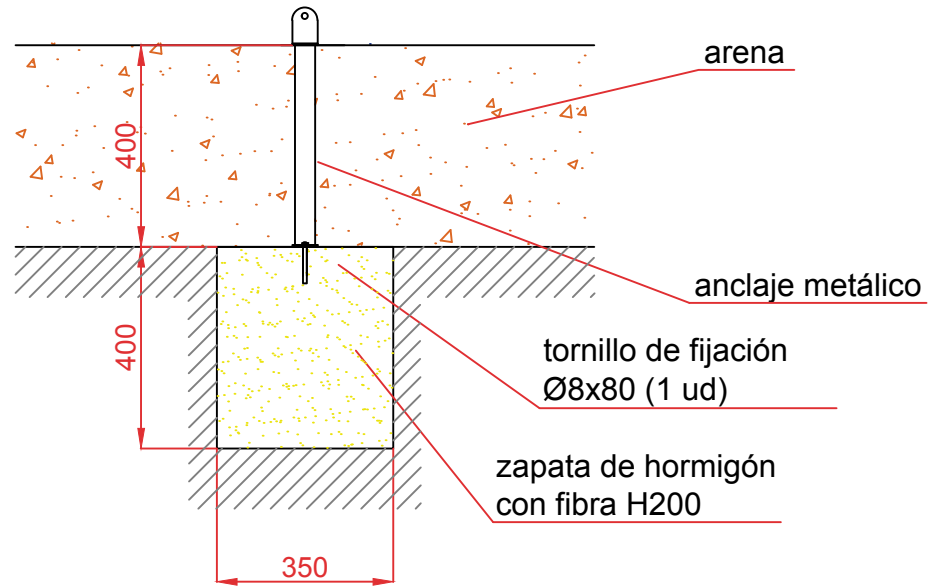

# PLANTA CIMENTACIÓN

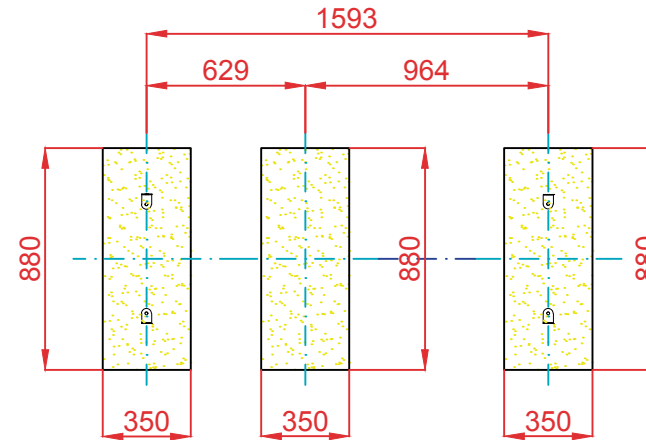

ESQUEMA DE CIMENTACIÓN  
EN HORMIGÓN  
E: 2/1

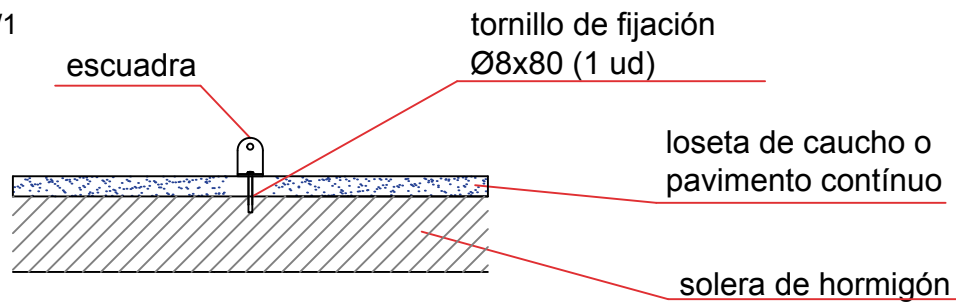

Dibujado		PLANO 2 CIMENTACIÓN Y ANCLAJES		Ref: TBG03
Revisado				
Aprobado				
Descripción:	TOBOGÁN "CÚBER"		Escala:	Nº Hoja 3/4
			Fecha:	08/08/2019

### ALZADO

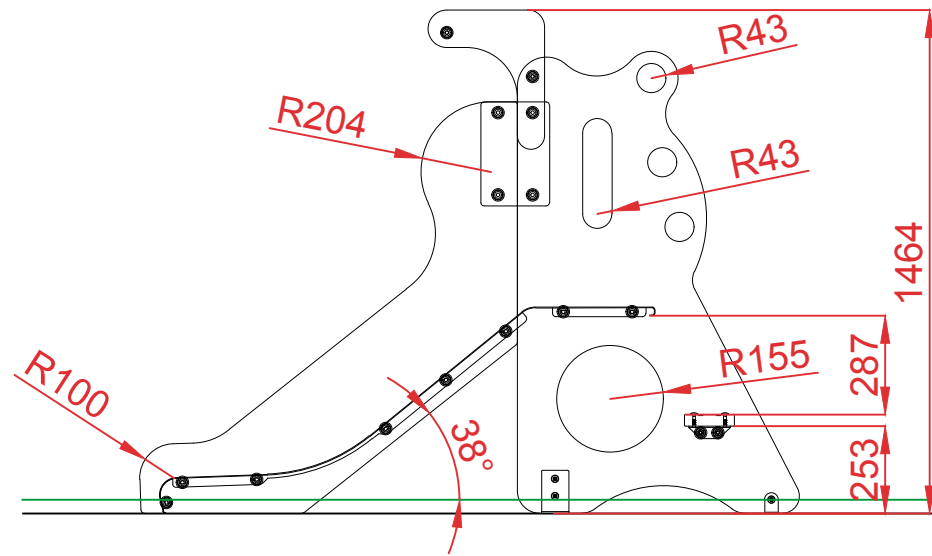

### PERFIL

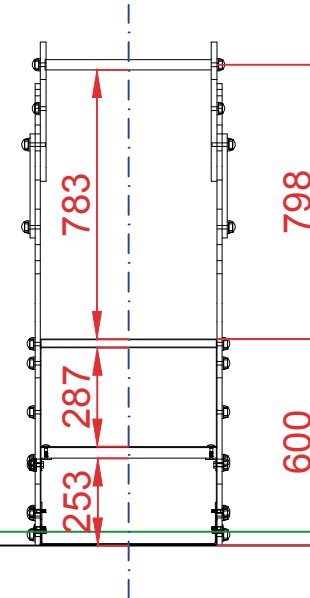

### PLANTA

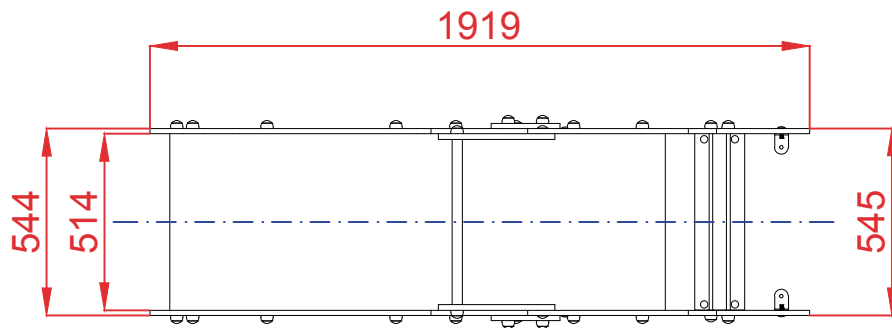

Dibujado		PLANO 3 VISTAS DE DETALLE		Ref: TBG03
Revisado				
Aprobado				
Descripción:	TOBOGÁN "CÚBER"	Escala:	Nº Hoja 4/4	
		Fecha:	08/08/2019	