

DOCUMENTACIÓN TÉCNICA



Ref.: TBG15

Tobogán "Palmera"

UNE-EN 1176 -1:2018

UNE-EN 1176 -3:2018

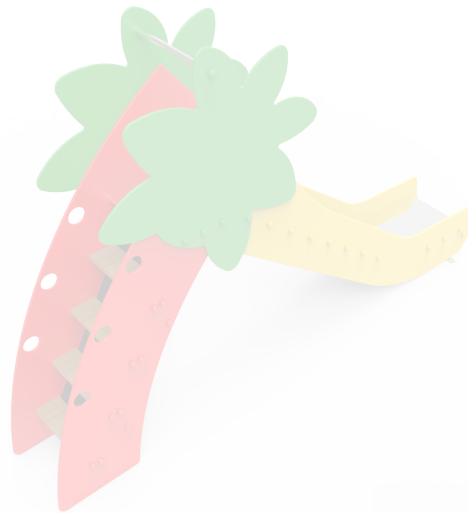

Altura libre de caída: 1,36 m

Edad recomendada de uso: a partir de 3 años

Componentes plásticos: Polietileno de alta densidad con protección UV

Rampa de tobogán: acero inoxidable

Tubo superior: acero inoxidable

Tornillería protegida con tapones de polipropileno

ALZADO

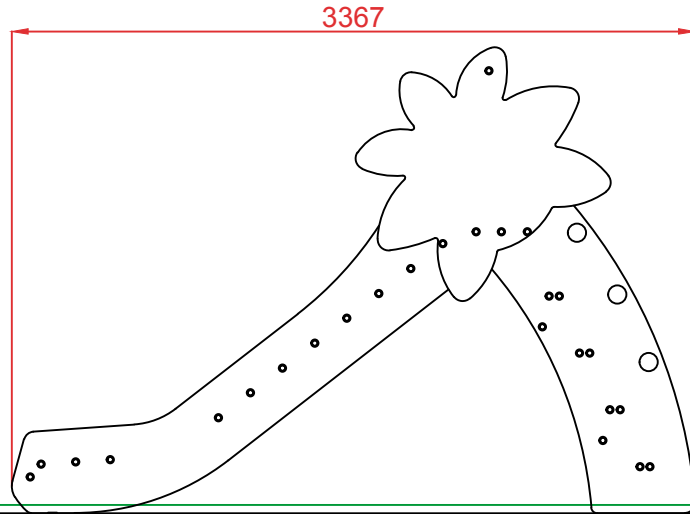

PERFIL

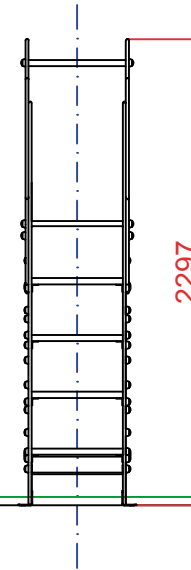

PLANTA

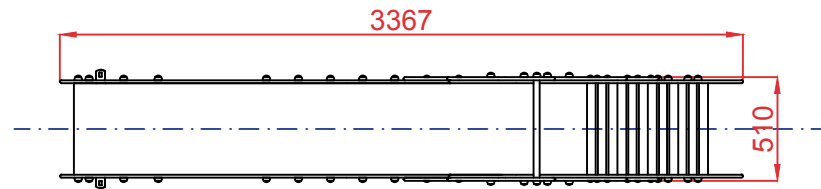

ÁREA DE SEGURIDAD
Superficie= 19 m²
E: 1/2

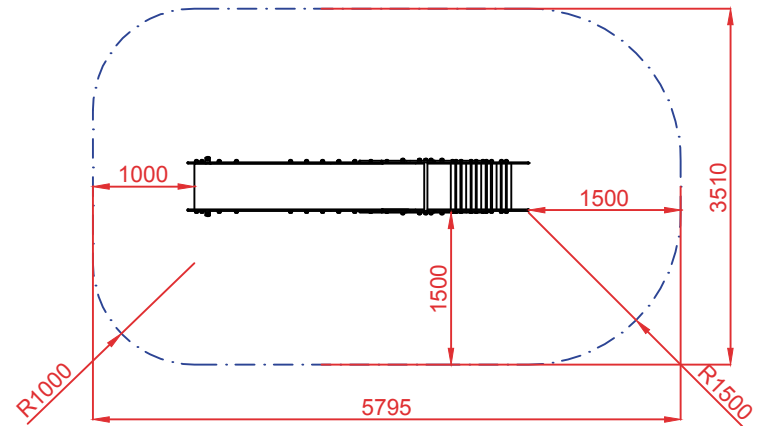

Dibujado		PLANO 1 VISTAS GENERALES	Ref:	TBG15
Revisado				
Aprobado				
Descripción:		TOBOGÁN "PALMERA"	Escala:	Nº Hoja 2/4
			Fecha:	09/05/2019

DETALLES CIMENTACIÓN

ESQUEMA DE CIMENTACIÓN
EN ARENA
E: 2/1

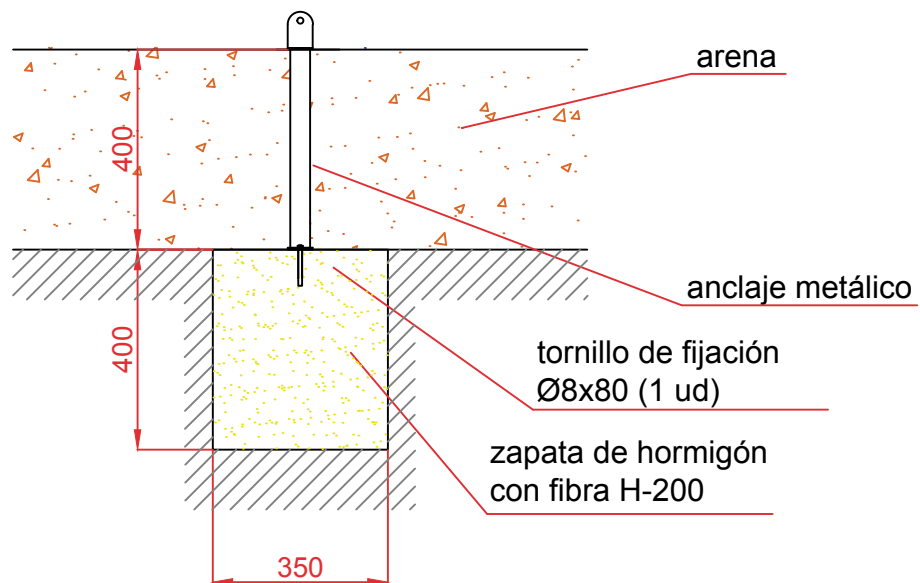

PLANTA CIMENTACIÓN

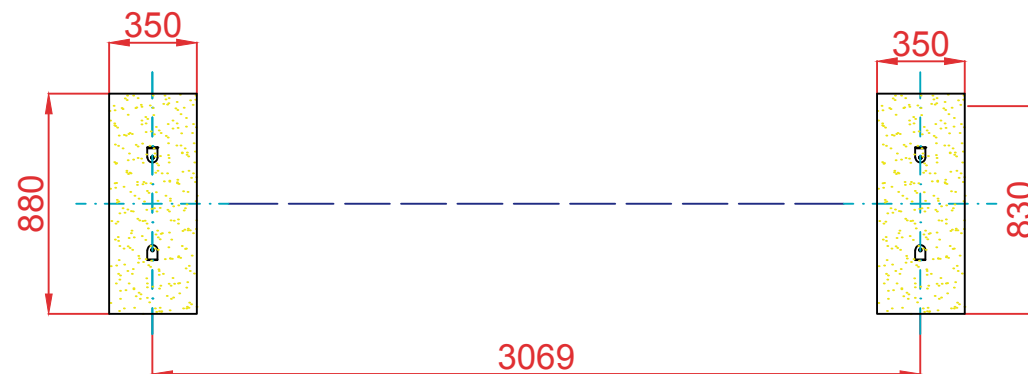

ESQUEMA DE CIMENTACIÓN
EN HORMIGÓN
E: 2/1

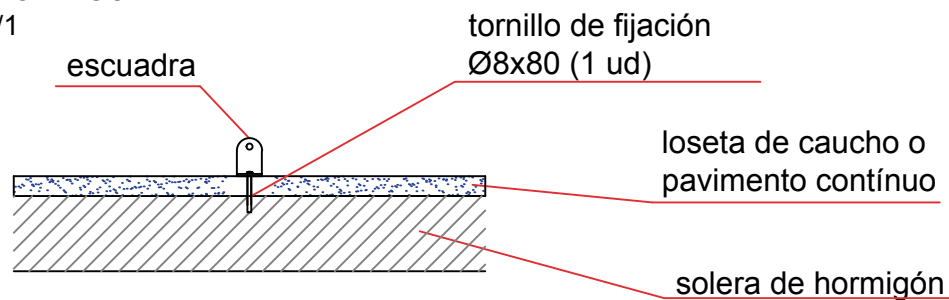

Dibujado		PLANO 2 CIMENTACIÓN Y ANCLAJES	Ref: TBG15	
Revisado				
Aprobado				
Descripción: TOBOGÁN "PALMERA"		Escala:	Nº Hoja 3/4	
		Fecha: 09/05/2019		

ALZADO

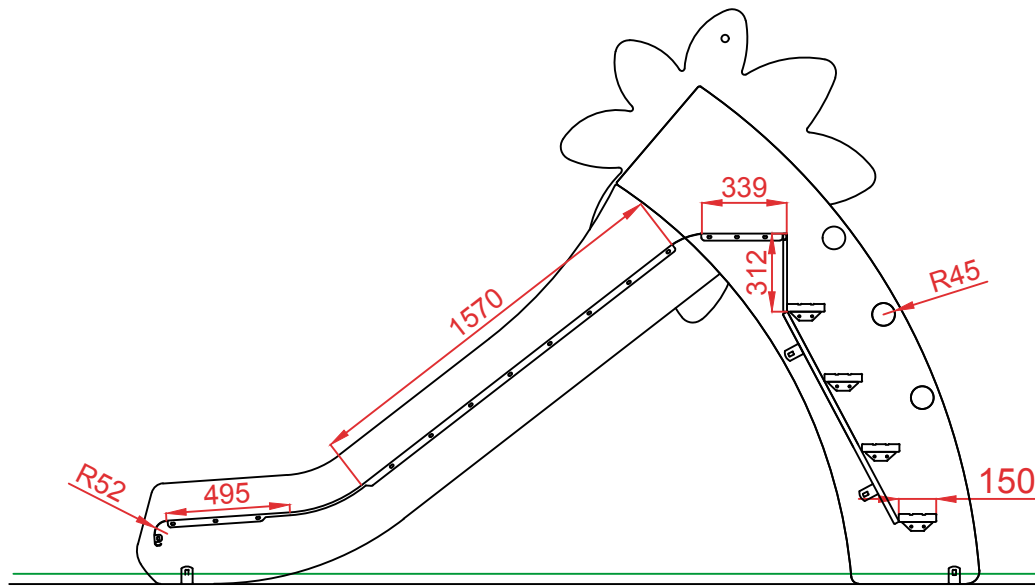

PERFIL

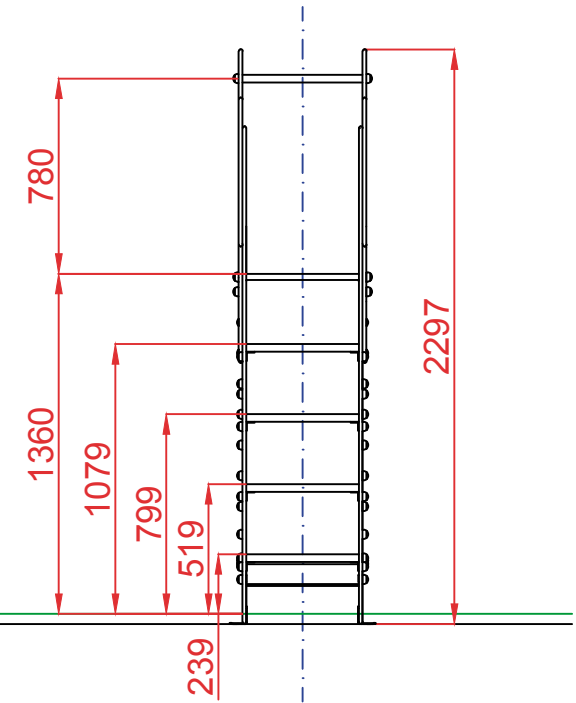

PLANTA

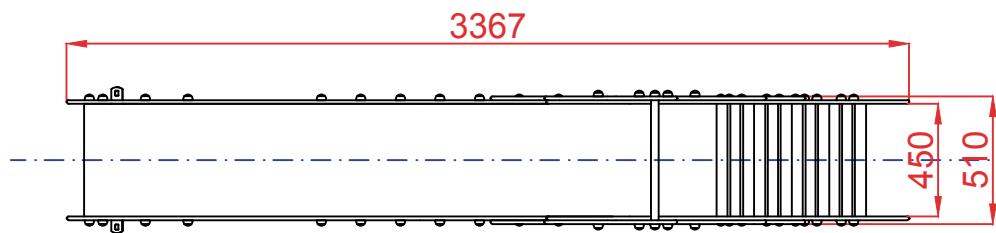

Dibujado		PLANO 3 VISTAS DE DETALLE		Ref: TBG15
Revisado				
Aprobado				
Descripción:		TOBOGÁN "PALMERA"	Escala:	Nº Hoja 4/4
			Fecha:	09/05/2019