

DOCUMENTACIÓN TÉCNICA



Ref.: TBG17

Tobogán "Palmera Baby"

UNE-EN 1176 -1:2018

UNE-EN 1176 -3:2018

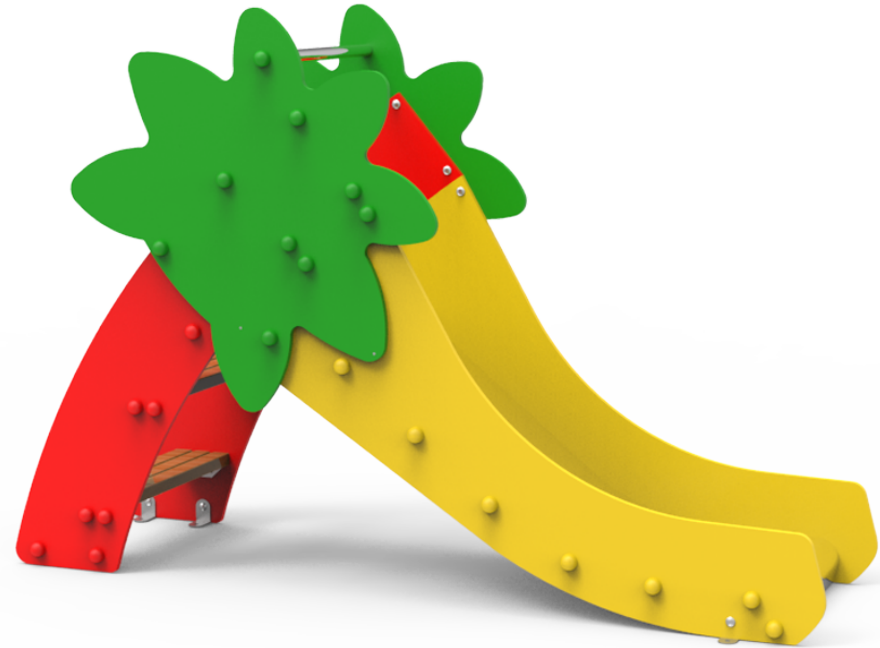

Altura libre de caída: 0,60 m

Edad recomendada de uso: a partir de 1 año

Madera de pino tratada en autoclave Nivel IV

Componentes plásticos: Polietileno de alta densidad con protección UV

Rampa de tobogán y barrera de protección de acero inoxidable

Componentes metálicos galvanizados

Tornillería protegida con tapones de polipropileno

ALZADO

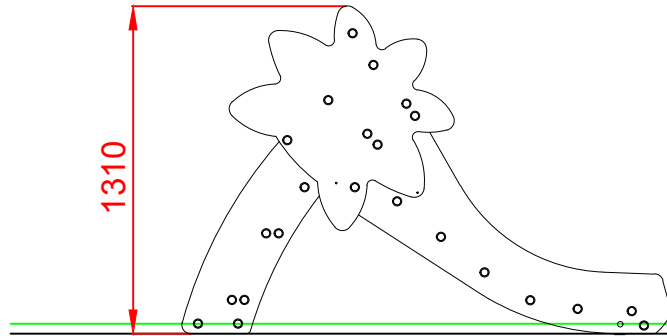

PERFIL IZQUIERDO

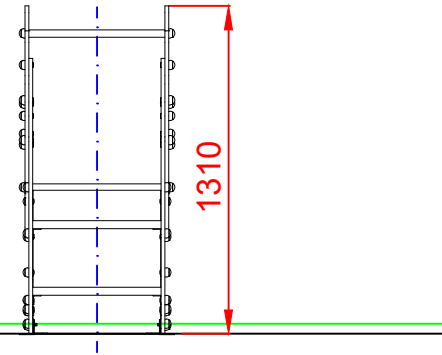

PLANTA

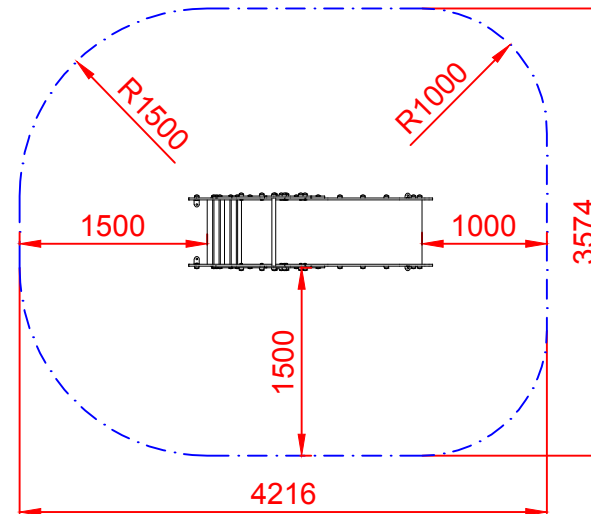
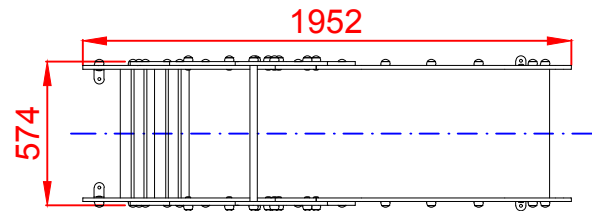

ÁREA DE SEGURIDAD
Superficie= 13,67 m²
E:1/2

Dibujado		PLANO 1 VISTAS GENERALES	Ref:	TBG17
Revisado				
Aprobado				
Descripción:		TOBOGÁN "PALMERA BABY"	Escala:	Nº Hoja 2/4
			Fecha:	09/12/2019



DETALLES CIMENTACIÓN

ESQUEMA DE CIMENTACIÓN
EN ARENA

E: 2/1

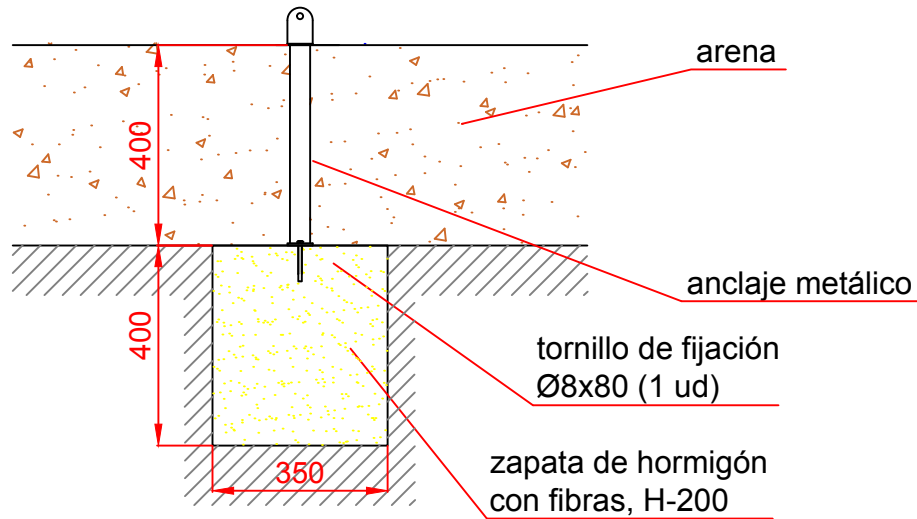

PLANTA CIMENTACIÓN

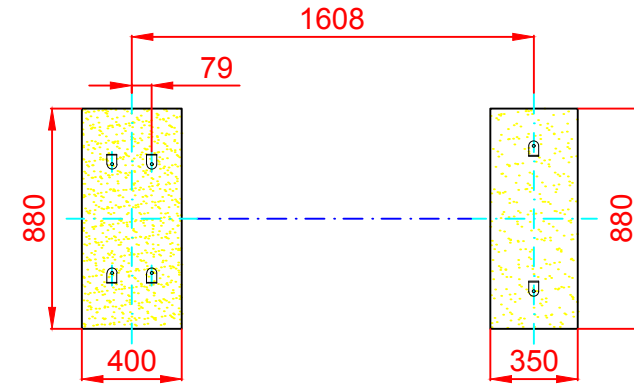

ESQUEMA DE CIMENTACIÓN
EN HORMIGÓN

E: 2/1

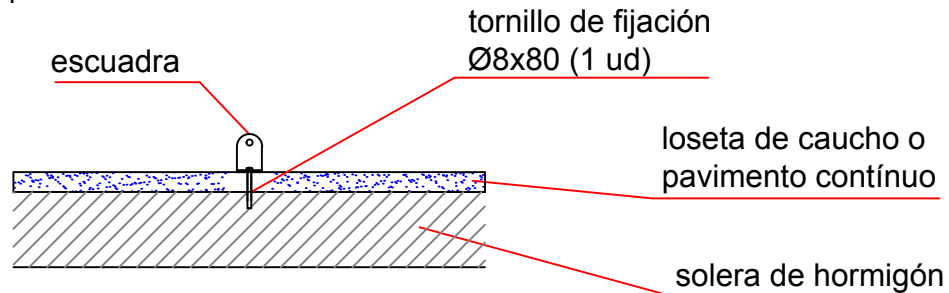

Dibujado		PLANO 2 CIMENTACIÓN Y ANCLAJES	Ref:	TBG17
Revisado				
Aprobado				
Descripción:		Escala:	Nº Hoja	
TOBOGÁN "PALMERA BABY"			3/4	
		Fecha:	09/12/2019	



ALZADO

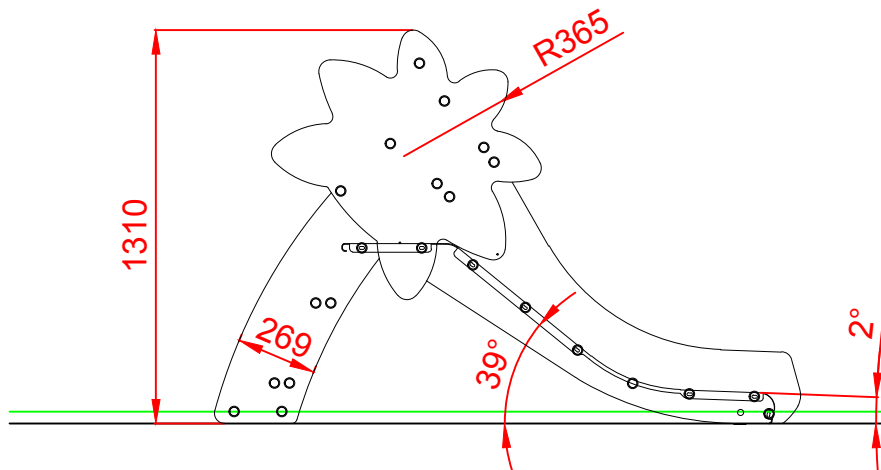

PERFIL IZQUIERDO

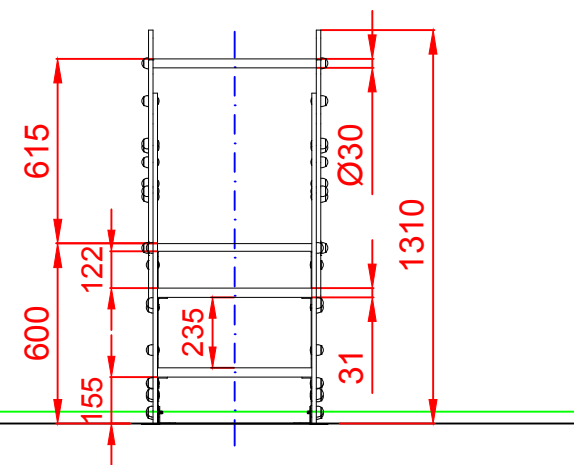

PLANTA

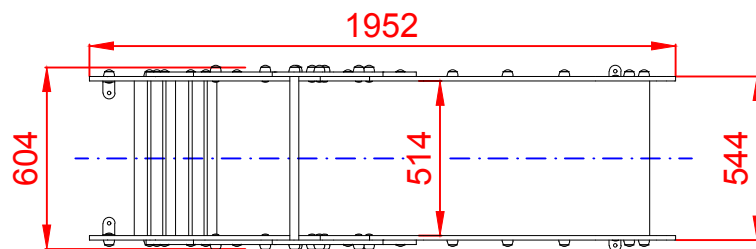

Dibujado		PLANO 3 VISTAS DE DETALLE	Ref:	TBG17
Revisado				
Aprobado				
Descripción:		Escala:	Nº Hoja	
TOBOGÁN "PALMERA BABY"			4/4	
		Fecha:	09/12/2019	