

# DOCUMENTACIÓN TÉCNICA



Ref.: VLL11

Puerta Valla Madera

UNE EN 1176-1:2018



Madera de pino tratada en autoclave Nivel IV  
Componentes plásticos: Polietileno de alta densidad con protección UV  
Componentes metálicos galvanizados

PERFIL DERECHO

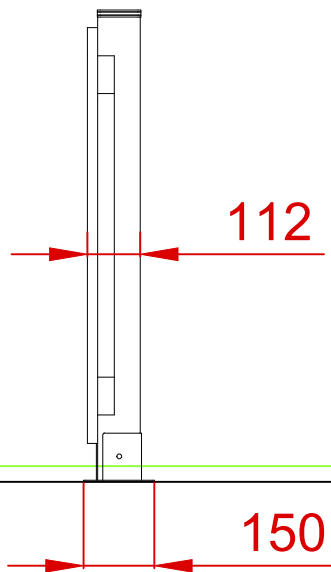

ALZADO

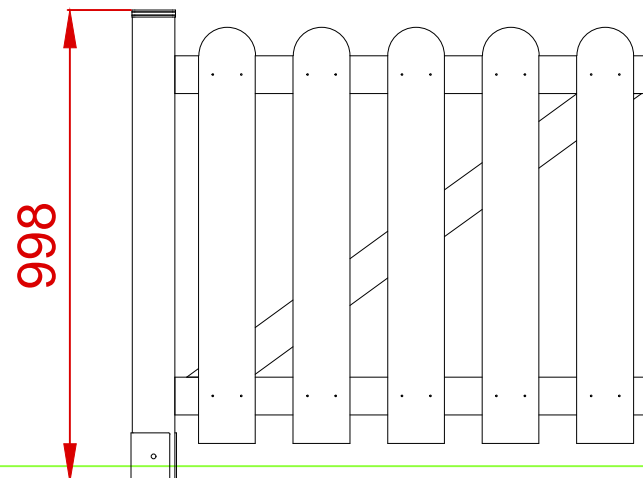

PLANTA

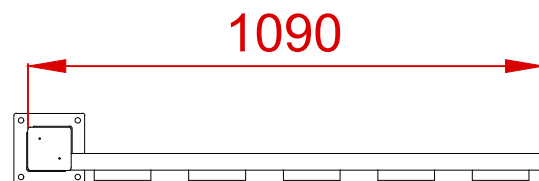

Dibujado		PLANO 1		Ref: VLL11
Revisado		VISTAS GENERALES		
Aprobado				
Descripción:			Escala:	Nº Hoja
PUERTA VALLA MADERA				2/3
			Fecha:	10/02/2022



# DETALLES CIMENTACIÓN

## ESQUEMA DE CIMENTACIÓN EN ARENA

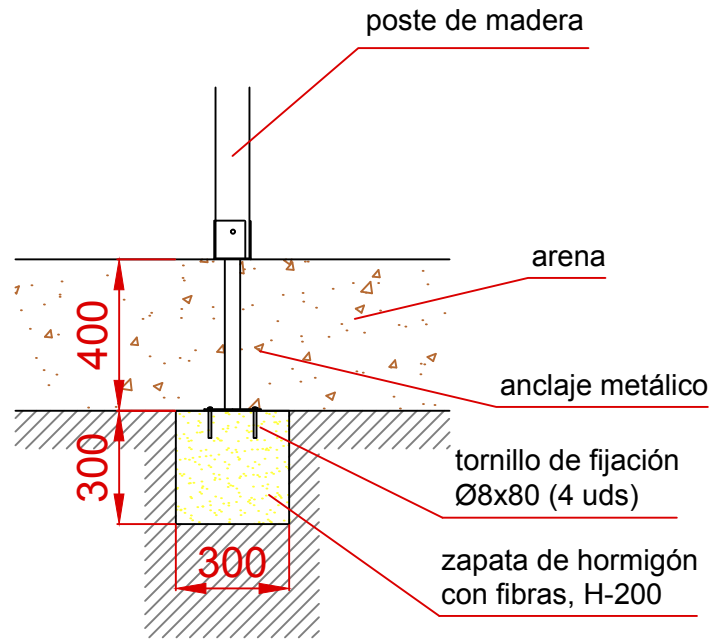

## PLANTA CIMENTACIÓN E: 2/1

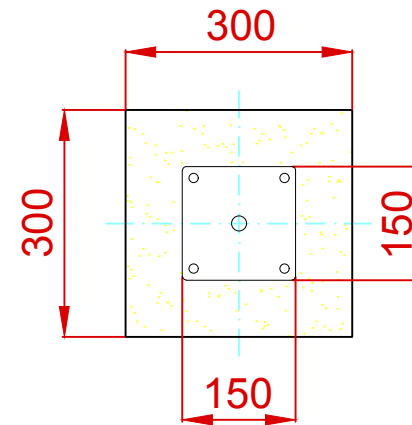

## ESQUEMA DE CIMENTACIÓN EN HORMIGÓN

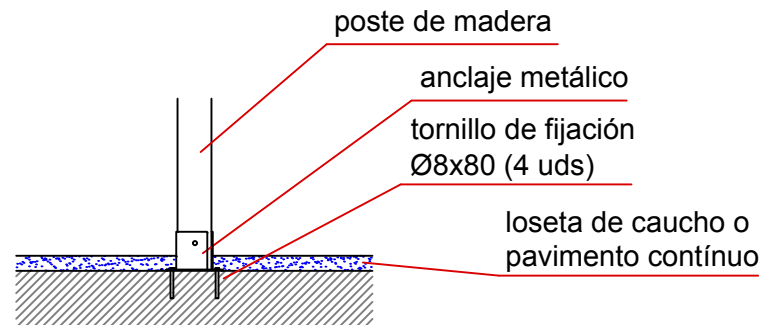

Dibujado		PLANO 2 CIMENTACIÓN Y ANCLAJES	Ref: VLL11
Revisado			
Aprobado			
Descripción:		Escala:	Nº Hoja
PUERTA VALLA MADERA			3/3
		Fecha:	10/02/2022